

Shanghai Mitsubishi Elevator Co.,Ltd.

Address: No.811 Jiangchuan Road.Minhang,Shanghai,China

Tel: +86-21-24083030/64303030

Fax: +86-21-24083088

Post: 200245

Overseas Business

Tel: +86-21-24083482

Fax: +86-21-24083488

E-mail: overseasbiz@smec-cn.com



www.smec-cn.com



Specifications subject to change without notice
Printed in Dec.2017.04

ELENESSA Series Machine-room-less Panoramic Elevator
LEHY-MRL Machine-room-less Panoramic Elevator
LEHY-III Panoramic Elevator with Machine Room

ELENESSA
PANORAMIC
ELEVATOR
LEHY-III LEHY-MRL

Panoramic Elevator

Grant Colorful Display of Building

Shanghai Mitsubishi's panoramic elevator gives the building its personality and vigor. No matter whether it is located outdoors or indoors, panoramic elevators would always catch people's eye. Passengers riding the elevator can easily overview the architecture style and ambient scenery. Its dynamic and colorful figure becomes fluid scenery in the building. Outstanding features can be found in outdoor enclosed or indoor open ELENESSA series、LEHY-MRL series、LEHY series panoramic elevators, no matter what kind of buildings where they are installed.

Innovative Concept Unique Design

Shanghai Mitsubishi has always been committed to the introduction of Mitsubishi technology, development and adaptation to the Chinese market with high-quality elevator products. Since its introduction of no machine room elevator technology in 2001, Mitsubishi Elevator has adhered to continuous improvement and innovation. A whole new generation ELENESSA passenger elevator without machine room, the extensive use of industry leading technology, Japan's Mitsubishi original development, is a new generation of global products. Shanghai Mitsubishi first made a dynamic introduction of the Japanese original technology, with the full application of sophisticated manufacturing technology and parts, implementing consistent and efficient, energy-saving, high-quality product concept, which reduces noise and reduce vibration, creating highly comfortable riding experience to passengers with a harmonious and comfortable living space, which has been highly praised by users. Ten years in a row it has been highly commended by market experts.

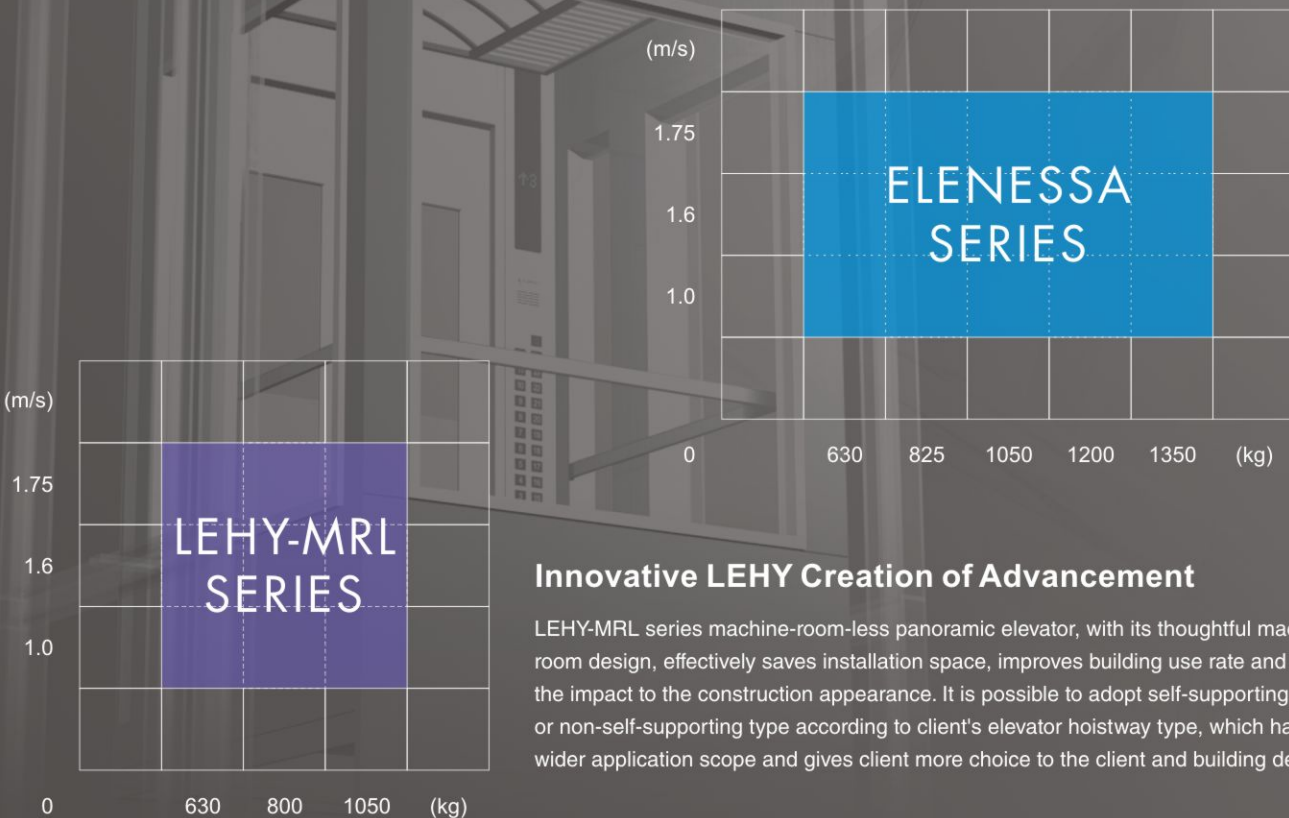

Innovative LEHY Creation of Advancement

LEHY-MRL series machine-room-less panoramic elevator, with its thoughtful machine room design, effectively saves installation space, improves building use rate and reduces the impact to the construction appearance. It is possible to adopt self-supporting type or non-self-supporting type according to client's elevator hoistway type, which has wider application scope and gives client more choice to the client and building design.

More Energy Saving More Comfortable

LEHY series compact machine room panoramic elevator combines Mitsubishi latest development and design concept and is integrated with PM synchronous traction technique; real compact machine room design; energy feedback based on dual-PWM control; voltage vector all-digit control; special frequency variable system and CAN bus technology. The product is therefore more energy efficient; more comfortable, and gives the construction infinite design freedom.

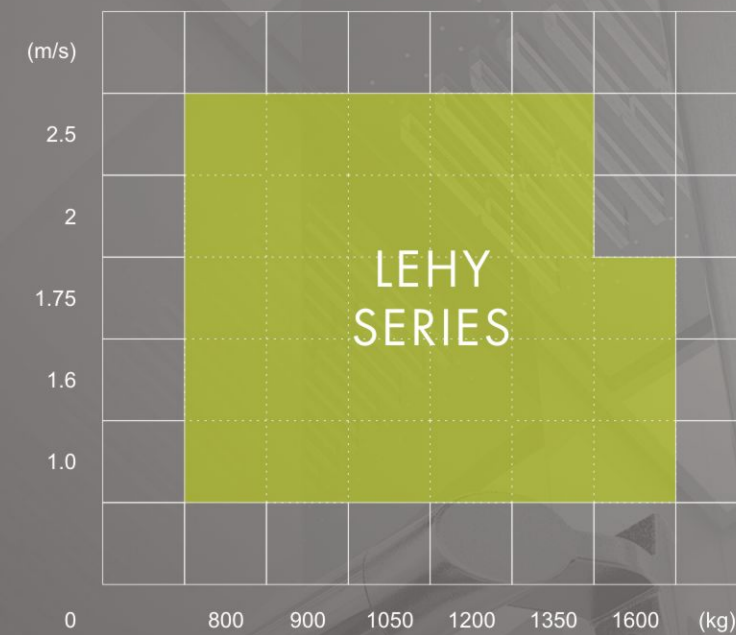

Integrative Car Design	P.03	ELENESSA DESIGN
Design of Car Roof	P.05	
Car Operation Panel	P.07	
Landing Display and Landing Call	P.10	
Integrative Car Design	P.13	LEHY-MRL/LEHY-III DESIGN
Design of Car Roof	P.17	
Car Operation Panel	P.19	
Landing Display and Landing Call	P.21	
Hall Design	P.25	GENERAL DESIGN
Corresponding Material	P.27	
LCD Display Series	P.29	
Basic Specification	P.30	SPECIFICATION
Safety and Secure Environment	P.33	SAFETY AND SECURE

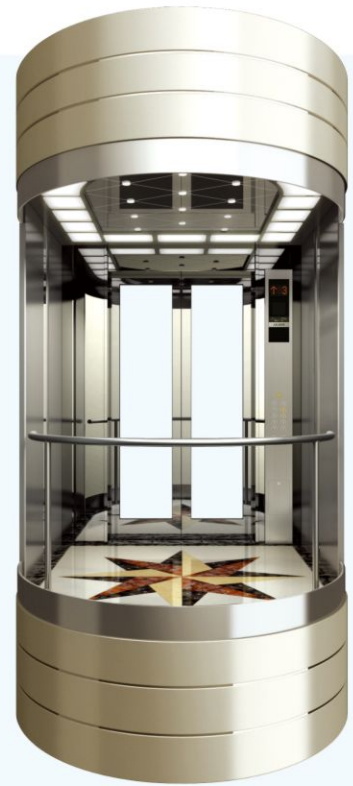

ELE-HY05S (825 kg, 1,050 kg)
(1.0 m/s, 1.6 m/s, 1.75 m/s)

- Observation Plane** Facade semi-circular ground observation (observation angle 180°).
- External Decoration Plate** Coated steel plate, metallic paint (drawing color No: ZJS-013G).
- External Decoration Lighting** Up&down step scagliola shim transparent lighting.
- Car Wall** Glass, hairline stainless steel, mirror stainless steel.
- Car Door Type** Standard door (center open), glass door ZPKG-150A (center open).
- Car door material** Hairline stainless steel, mirror stainless steel... (see P28 "Car material configuration table" for detail)
- Car ceiling** STD, SPD (car ceiling shown in figure: STD).
- Handrail** Facade hairline stainless steel round handrail (only in observation plane), Facade mirror stainless steel round handrail (only in observation plane).
- Floor** PVC stone , concave car bottom. (Non-standard parquet floor/shown in figure: ZPH-001)



ELE-NZ31S (825 kg, 1,050 kg)
(1.0 m/s, 1.6 m/s, 1.75 m/s)



- Observation Plane** Three-sided floor-standing observation.
- External Decoration Plate** Coated steel plate, hairline stainless steel... (see P28 "Car material configuration table" for detail)
- External Decoration Lighting** None.
- Car Wall** Glass, hairline stainless steel, mirror stainless steel... (see P28 "Car material configuration table" for detail)
- Car Door Type** Standard door (center open), glass door (center open).
- Car door material** Hairline stainless steel, mirror stainless steel... (see P28 "Car material configuration table" for detail)
- Car ceiling** S00, S200, L200, L200S, L210, L210S, S300, N120, N130, N140, N300, N300S, L310, L400. (Car ceiling shown in figure: L310)
- Handrail** Three-sided hairline stainless steel round handrail, Three-sided mirror stainless steel round handrail.
- Floor** PVC stone , parquet floor, concave car bottom (3-25mm). (Parquet shown in figure : ZPH-004)

ELE-NZ10S (630 kg, 825 kg, 1,050 kg)
(1.0 m/s, 1.6 m/s, 1.75 m/s)



- Observation Plane** Observation from windows at front side.
- External Decoration Plate** Coated steel plate (drawing color no: Y033), hairline stainless steel... (see P28 "Car material configuration table" for detail)
- External Decoration Lighting** None.
- Car Wall** Glass, hairline stainless steel, mirror stainless steel... (see P28 "Car material configuration table" for detail)
- Car Door Type** Standard door (center open/side open), glass door (center open).
- Car door material** Hairline stainless steel, mirror stainless steel... (see P28 "Car material configuration table" for detail)
- Car ceiling** S00, S200, L200, L200S, L210, L210S, S300, N120, N130, N140, N300, N300S, L310, L400. (Car ceiling shown in figure: N120)
- Handrail** Facade hairline stainless steel round handrail, facade mirror stainless steel round handrail.
- Floor** PVC stone , parquet floor, concave car bottom (3-25mm).



ELE-NZ32S (1,200 kg, 1,350 kg)
(1.0 m/s, 1.6 m/s, 1.75 m/s)



- Observation Plane** All-round floor-standing observation (without newels at corners).
- External Decoration Plate** Coated steel plate, hairline stainless steel... (see P28 "Car material configuration table" for detail)
- External Decoration Lighting** None.
- Car Wall** Glass, hairline stainless steel, mirror stainless steel... (see P28 "Car material configuration table" for detail)
- Car Door Type** Glass door ZPKG-050A (center open).
- Car door material** Hairline stainless steel, mirror stainless steel... (see P28 "Car material configuration table" for detail)
- Car ceiling** S00, S200, L200, L200S, L210, L210S, S300, N120, N130, N140, N300, N300S, L310. (Car ceiling shown in figure: N300)
- Handrail** Three-sided hairline stainless steel round handrail, Three-sided mirror stainless steel round handrail.
- Floor** PVC stone , parquet floor, concave car bottom (3-25mm). (Parquet shown in figure : ZPH-001)



L400*1



Car ceiling: Central milky white coated steel plate + ambient coated steel plate (Y055).

Lighting: Central floodlighting (LED) + ambient milky white acrylic light transmittance.

N300/N300S*1



Car Ceiling: Coated steel plate (Y033) (N300)/Hairline stainless steel(N300S).

Lighting: Central floodlight (LED) + corners spotlight (LED).

N130*1

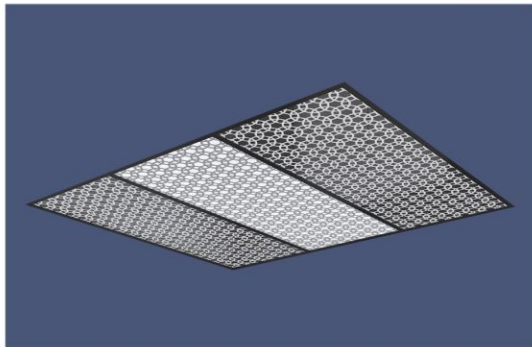

Car Ceiling: silk patterned acrylic sheet.

Lighting: Full illumination (LED).

N140*1

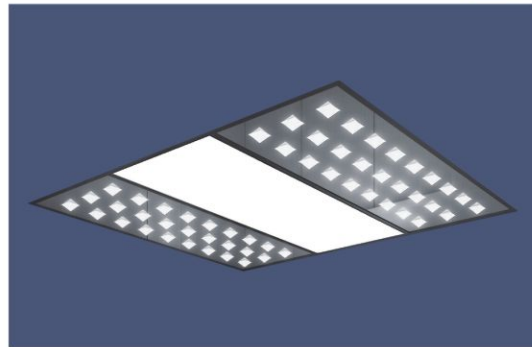

Car Ceiling: Central milky white acrylic plate, the side mirror panels with a diamond-shaped three-dimensional trim.

Lighting: Full illumination (LED).

L200/L200S*1

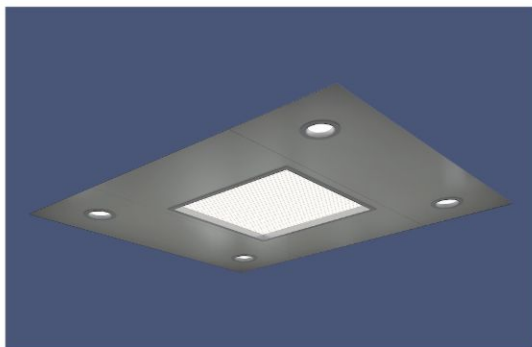

Car Ceiling: Coated steel plate(L200) / hairline stainless steel (L200S).

Lighting: Central lighting grid-like crystal plate + corners down lights (LED).

L210/L210S*1

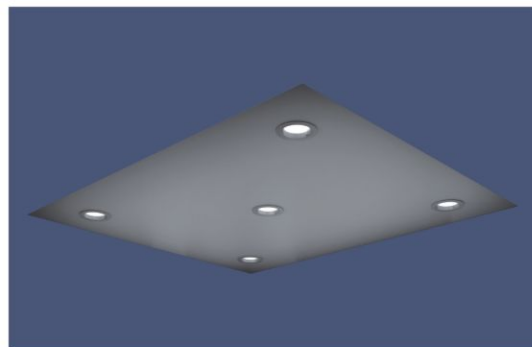

Car Ceiling: Coated steel plate(L210) / hairline stainless steel (L210S).

Lighting: down light (LED).

N120*1

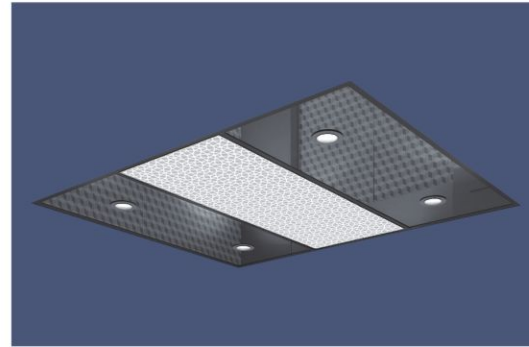

Car Ceiling: Central printing pattern acrylic plate, acrylic plate side.

Lighting: Central full illumination (LED) + corners down lights.

L310*1

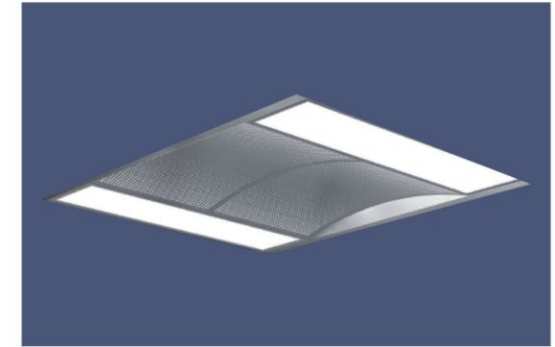

Car Ceiling: central arch mesh lighting panel + milky white acrylic panels on both sides.

Lighting: Translucent lighting (LED).

S00*1

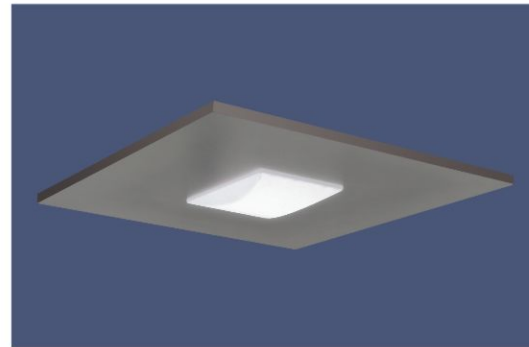

Car Ceiling: Coated steel plate *2.

Lighting: Central milky white acrylic shade.

STD (only applicable to ELE-HY05S)*1

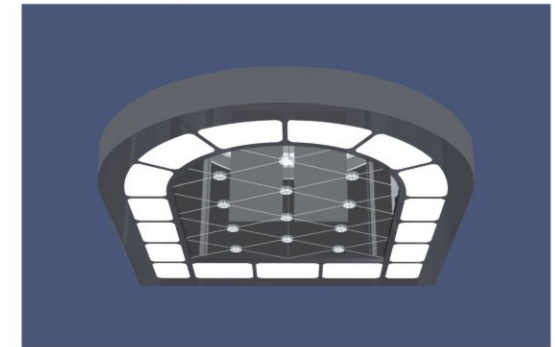

Car Ceiling: Coated steel plate *2.

Lighting: Central lines etched mirror stainless steel +organic lamppost, ambient milky white resin plate.

Ventilation: air ducts on both sides and cross-flow fan.

SPD (only applicable to ELE-HY05S)*1

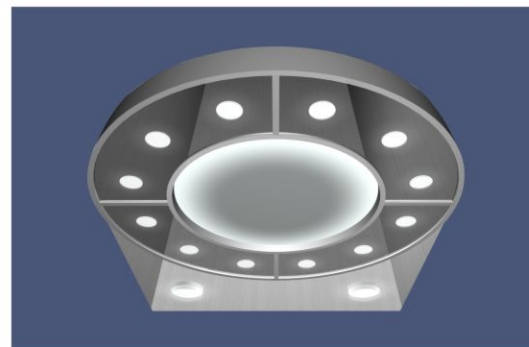

Car Ceiling: Central Coated steel plate(ZY005), inlet side mirror stainless steel.

Lighting: Central floodlighting + organic lamppost translucent lighting.

Ventilation: air ducts on both sides and cross-flow fan.

S200 (Vacant car ceiling)*1

Customer's choice for decoration (recommended ceiling height 100mm)
For customer's decoration, there are certain restrictions to weights, please contact the sales staff in advance.

S300 (Vacant car ceiling)*1

Customer's choice for decoration (recommended ceiling height 200mm)
For customer's decoration, there are certain restrictions to weights, please contact the sales staff in advance.

Note: *1 Applicable to ELENESSA series.

*2 Use the color number according to Shanghai Mitsubishi Decoration Plate.

Front Wall Half-length Operation panel

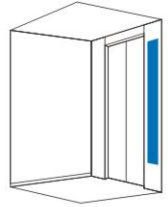

Available when front wall width ≥ 250 .



CBV■-C720*1*3*4
(Main)
CBV■-C726*2*3*5
(Auxiliary)

Hairline stainless steel faceplate.
Round stainless steel button.
Dot-array LED display.

CBV■-CS10*1*3*4
(Main)
CBV■-CS16*2*3*5*6
(Auxiliary)

Hairline stainless steel faceplate.
Round stainless steel button.
5.7 inch color segment LCD display.

CBV■-C730*1*3*4
(Main)
CBV■-C736*2*3*5
(Auxiliary)

Hairline stainless steel faceplate.
Round stainless steel button.
HD 5.7 inch TFT LCD Display.

CBV■-CS30*1*3*4
(Main)
CBV■-CS36*2*3*5
(Auxiliary)

Hairline stainless steel faceplate.
Round stainless steel button.
HD 5.7 inch TFT LCD Display.

Side Wall Full-length Operation Panel (Comply with GB/T24477 Standard)

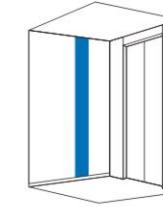

CBV■-CS00*1*3*4
(Main)
CBV■-CS06*2*3*5
(Auxiliary)

Hairline stainless steel faceplate.
Round stainless steel button.
HD 8.4 inch TFT LCD Display.

CBV■-N720*7
(Main)
CBV■-N726*6*7
(Auxiliary)

Hairline stainless steel faceplate.
Round stainless steel button.
Dot-array LED display.

CBV■-NS10*7
(Main)
CBV■-NS16*6*7
(Auxiliary)

Hairline stainless steel faceplate.
Round stainless steel button.
5.7 inch color segment LED display.

CBV■-N730*7
(Main)
CBV■-N736*6*7
(Auxiliary)

Hairline stainless steel faceplate.
Round stainless steel button.
HD 5.7 inch TFT LCD Display.

Note: *1 Applicable to ELE-NZ10S, (center open and load weight ≥ 630 kg) or (side open and (AA-JJ-25) ≥ 250 and load weight ≥ 630 kg).
*2 Applicable to ELE-NZ10S, center open and load weight ≥ 630 kg.
*3 Applicable to ELE-HY05S, load weight is 1050kg.
*4 Applicable to ELE-NZ31S.
*5 Applicable to ELE-NZ31S, door open type is 1D1G.

Note: *6 Non-standard.
*7 Applicable to ELE-HY05S 825kg capacity, ELE-NZ10S, ELE-NZ32S.
Symbol ■ is button type, please select and fill in from page "12", selection scope is CBV1-CBV6.
LED display see "page 29".

Side Wall Full-length Operation Panel (Comply with GB/T24477 Standard)

CBV-NS30*2 (Main)
CBV-NS36*1*2 (Auxiliary)
Hairline stainless steel faceplate.
Round stainless steel button.
HD 5.7 inch TFT LCD Display.

CBV-NS00*2 (Main)
CBV-NS06*1*2 (Auxiliary)
Hairline stainless steel faceplate.
Round stainless steel button.
HD 8.4 inch TFT LCD Display.

Wheelchair operation panel

CBV-F690*1
Hairline stainless steel faceplate.
Round stainless steel button.
Dot-array LED display.
Intercom device.
(without VIP-S function, without SCS-IC function)

CBV-F600*1
Hairline stainless steel faceplate.
Round stainless steel button.
HD 4.3 inch TFT LCD Display.
(without VIP-S function, without SCS-IC function)

LED dot-array landing display and landing call

PIV-A730N*3 (without box)
Plastic faceplate.
Round stainless steel button.
Dot-array LED display.
unable to provide key switch.

PIV-A740N*3 (without box)
Plastic faceplate.
Round stainless steel button.
Dot-array LED display.
unable to provide key switch.
For parallel connection or group control.

PIV-A730B*3
Plastic faceplate.
Round stainless steel button.
Dot-array LED display.
able to provide one key switch.

PIV-A740B*3
Plastic faceplate.
Round stainless steel button.
Dot-array LED display.
able to provide two key switches.
For parallel connection or group control.

PIV-C730N*3
Hairline stainless steel button.
Round stainless steel button.
Dot-array LED display.
able to provide one key switch.

PIV-C740N*3
Hairline stainless steel button.
Round stainless steel button.
Dot-array LED display.
able to provide two key switches.
For parallel connection or group control.

4.3 inch LCD landing display and landing call

PIV-CS60N*3
Hairline stainless steel button.
Round stainless steel button.
HD 4.3 inch TFT LCD display.
able to provide one key switch.

PIV-CS70N*3
Hairline stainless steel button.
Round stainless steel button.
HD 4.3 inch TFT LCD display.
able to provide two key switches.

PIV-CS10N*3
Hairline stainless steel button.
Round stainless steel button.
4.3 inch TFT LCD display.
able to provide one key switch.

PIV-CS20N*3
Hairline stainless steel button.
Round stainless steel button.
4.3 inch TFT LCD display.
able to provide two key switches.

PIV-CS80N*3
Hairline stainless steel button.
Round stainless steel button.
HD 4.3 inch TFT LCD display.
able to provide one key switch.

PIV-CS90N*3
Hairline stainless steel button.
Round stainless steel button.
HD 4.3 inch TFT LCD display.
able to provide two key switches.

Note: *1 Non-standard.

*2 Applicable to ELE-HY05S 825kg capacity, ELE-NZ10S, ELE-NZ32S.

Symbol ■ is button type, please select and fill in from page "12", selection scope is CBV1-CBV6.

LED display see "page 29".

Note: *1 Applicable to ELE-HY05S, ELE-NZ10S, ELE-NZ31S.

Symbol ● is button type, please select buttons and fill in from page "12".

The pictures are drawn by computer, which may be slightly different from the actual.

Landing call



Column landing call

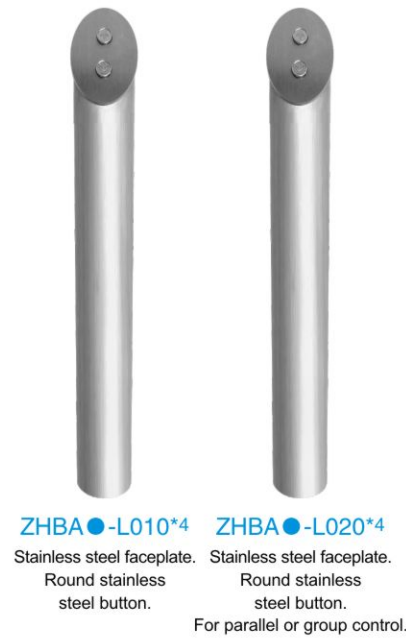

LED dot-array landing indicator



LCD landing indicator



Note: *1 Applicable to ELE-HY05S, ELE-NZ10S, ELE-NZ31S
*2 Applicable to ELE-HY05S, ELE-NZ10S, ELE-NZ31S, and landing indicator is large indicator without buttons or landing prediction lantern.
*3 Non-standard, with wheelchair operation panel.
*4 With ELE-NZ32S, and landing indicator is large indicator without buttons or landing prediction lantern.
*5 See "P29" for LCD display.
*6 Non-standard
Symbol ● is button type, please select buttons and fill in from page "12".

Landing direction lantern

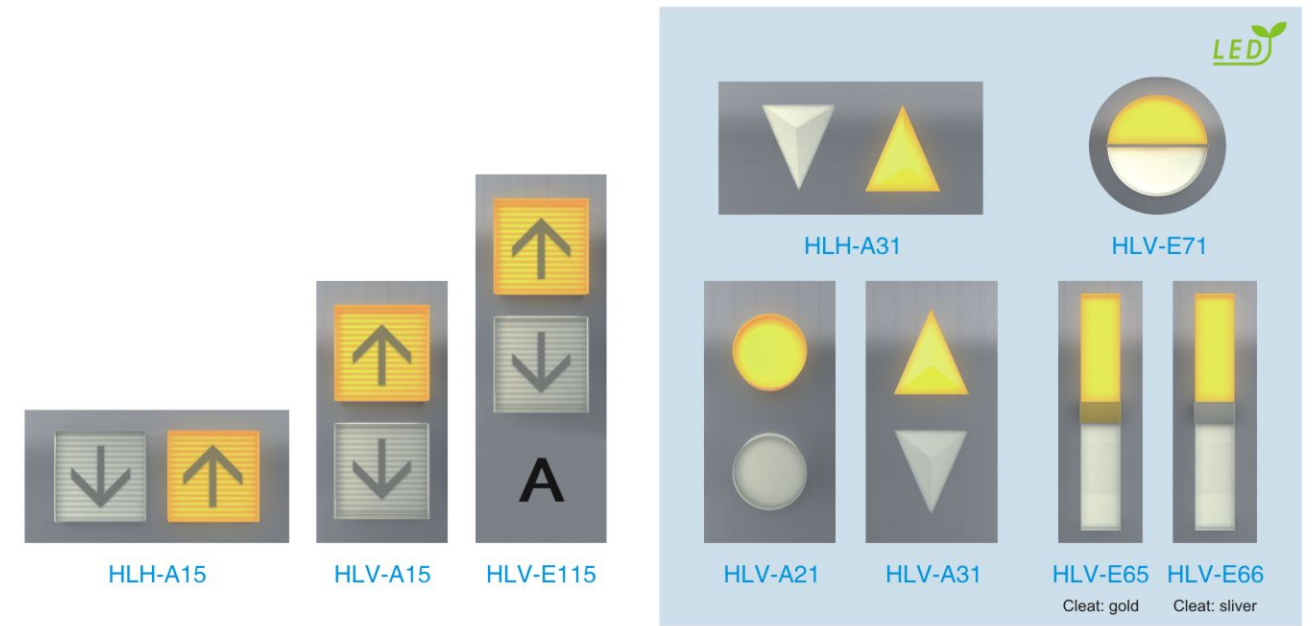

Buttons

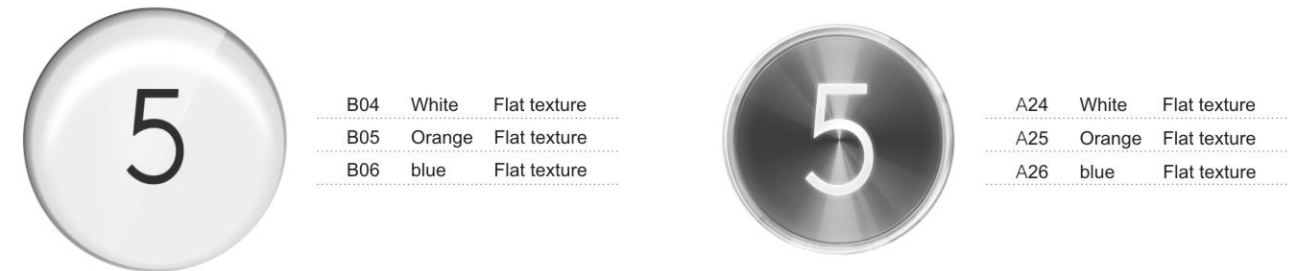

Note: Diameter Φ50, non-standard.
Only for floors less than 12.
With wheelchair operation panel, only for floors less than 8.

Type	Model	Explanation	Luminous color	Remark
High-touch style	CBV1/PIV1/HBV1	Stainless steel irregular-polished decoration plane. Convex texture button.	Orange-yellow	
	CBV3/PIV3/HBV3		White	
	CBV5/PIV5/HBV5		Blue	
Flat type	CBV2/PIV2/HBV2	Stainless steel irregular-polished decoration plane. Flat texture button.	Orange-yellow	Flat button isn't applicable for EN81-70.
	CBV4/PIV4/HBV4		White	
	CBV6/PIV6/HBV6		Blue	

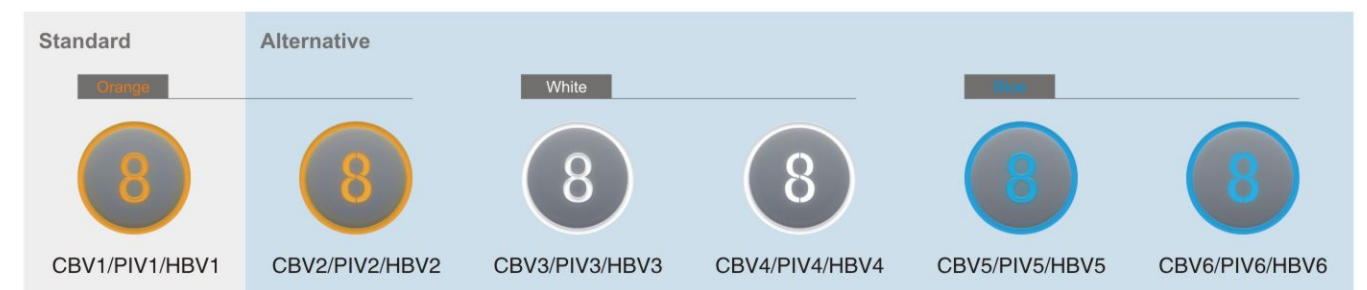

Note: Diameter Φ36 (with button loop)



LEHY-MRL-NZ10S (630kg, 800kg, 1050kg)
(1.0m/s, 1.6m/s, 1.75m/s)



- Observation Plane** Facade window observation.
- External Decoration Material** Coated steel plate, hairline stainless steel, mirror stainless steel.
- External Decoration Lighting** None.
- Car Wall** Glass, coated steel plate, hairline stainless steel... (see P28 "Car material configuration table" for detail)
- Car Door Type** Standard door (center open), Glass door (center open).
- Car door material** Coated steel plate, laminated steel plate... (see P28 "Car material configuration table" for detail)
- Car ceiling** ZCL-DS12, ZCL-GS08, ZCL-GS16, ZCL-DS13, ZCL-GN04, ZCL-GN05, ZCL-GS06, ZCL-GN02, ZCL-GN03, ZCL-SS06, ZCL-SS08, ZCL-SN03, ZCL-SS07, ZCL-CN01 (Null), ZCL-CN08 (Null). (Car ceiling shown in the picture: ZCL-SN03)
- Handrail** Facade hairline stainless steel round handrail.
- Floor** PVC stone floor, concave car bottom(3-25mm), parquet floor.



LEHY-MRL-NZ31S (630kg, 800kg, 1050kg)
(1.0m/s, 1.6m/s, 1.75m/s)



- Observation Plane** Three-sided large ground observation.
- External Decoration Material** Coated steel plate, hairline stainless steel, mirror stainless steel.
- External Decoration Lighting** None.
- Car Wall** Glass, coated steel plate, hairline stainless steel... (see P28 "Car material configuration table" for detail)
- Car Door Type** Standard door (center open), Glass door (center open).
- Car door material** Coated steel plate, laminated steel plate... (see P28 "Car material configuration table" for detail)
- Car ceiling** ZCL-DS12, ZCL-GS08, ZCL-GS16, ZCL-DS13, ZCL-GN04, ZCL-GN05, ZCL-GS06, ZCL-GN02, ZCL-GN03, ZCL-SS06, ZCL-SS08, ZCL-SN03, ZCL-SS07, ZCL-CN01 (null), ZCL-CN08 (null). (Car ceiling shown in the picture: ZCL-GN04)
- Handrail** Three-sided hairline stainless steel round handrail.
- Floor** PVC stone floor, concave car bottom(3-25mm), parquet floor.

LEHY-MRL-NZ11S (630kg, 800kg, 1050kg)
(1.0m/s, 1.6m/s, 1.75m/s)



- Observation Plane** Facade large ground observation.
- External Decoration Material** Coated steel plate, hairline stainless steel, mirror stainless steel.
- External Decoration Lighting** None.
- Car Wall** Glass, coated steel plate, hairline stainless steel... (see P28 "Car material configuration table" for detail)
- Car Door Type** Standard door (center open), Glass door (center open).
- Car door material** Coated steel plate, laminated steel plate... (see P28 "Car material configuration table" for detail)
- Car ceiling** ZCL-DS12, ZCL-GS08, ZCL-GS16, ZCL-DS13, ZCL-GN04, ZCL-GN05, ZCL-GS06, ZCL-GN02, ZCL-GN03, ZCL-SS06, ZCL-SS08, ZCL-SN03, ZCL-SS07, ZCL-CN01 (null), ZCL-CN08 (null). (Car ceiling shown in the picture: ZCL-GN03)
- Handrail** Facade hairline stainless steel round handrail.
- Floor** PVC stone floor, concave car bottom(3-25mm), parquet floor. (Parquet shown in the picture: ZSC-001)



LEHY-III-S1 (800kg, 900kg, 1050kg, 1200kg, 1350kg)
(1.0m/s, 1.6m/s, 1.75m/s, 2.0m/s, 2.5m/s)



- Observation Plane** Facade window observation.
- External Decoration Material** Coated steel plate.
- External Decoration Lighting** None.
- Car Wall** Glass, film-mounting steel plate, coated steel plate, hairline stainless steel, handrail etched stainless steel.
- Car door material** Film-mounting steel plate, coated steel plate, hairline stainless steel, handrail etched stainless steel, mirror etched stainless steel.
- Car ceiling** ZCL-DS12, ZCL-GS08, ZCL-GS16, ZCL-DS13, ZCL-GN04, ZCL-GN05, ZCL-GS06, ZCL-GN02, ZCL-GN03, ZCL-SS06, ZCL-SS08, ZCL-SN03, ZCL-SS07, ZCL-CN01 (null), ZCL-CN08 (null). (Car ceiling shown in the picture: ZCL-GN02)
- Handrail** Facade hairline stainless steel round handrail.
- Floor** PVC stone floor, concave car bottom(3-25mm), parquet floor, marble terrace.





LEHY-III-S2 (800kg, 1050kg, 1200kg, 1350kg)
(1.0m/s, 1.6m/s, 1.75m/s, 2.0m/s, 2.5m/s) 

- Observation Plane** Facade and two-sided front window observation.
- External Decoration Material** Coated steel plate.
- External Decoration Lighting** None.
- Car Wall** Glass, film-mounting steel plate, coated steel plate, hairline stainless steel, handrail etched stainless steel.
- Car door material** Film-mounting steel plate, coated steel plate, hairline stainless steel, handrail etched stainless steel, mirror stainless steel, mirror etched stainless steel.
- Car ceiling** ZCL-DS12, ZCL-GS08, ZCL-GS16, ZCL-DS13, ZCL-GN04, ZCL-GN05, ZCL-GS06, ZCL-GN02, ZCL-GN03, ZCL-SS06, ZCL-SS08, ZCL-SN03, ZCL-SS07, ZCL-CN01 (Null), ZCL-CN08 (Null). (Car ceiling shown in the picture: ZCL-GS06)
- Handrail** Hairline stainless steel round handrail (facade +glass at two sides).
- Floor** PVC stone floor, concave car bottom(3-25mm), parquet floor, marble terrace.



LEHY-III-HY06S (1050kg, 1200kg, 1350kg, 1600kg)
(1.0m/s, 1.6m/s, 1.75m/s)

- Observation Plane** Car all-round observation.
- External Decoration Material** Coated steel plate, hairline stainless steel, mirror stainless steel.
- External Decoration Lighting** None.
- Car Wall** Glass, hairline stainless steel, mirror stainless steel.
- Car door type** Glass door (ZPKG-150A), standard door.
- Car door material** Hairline stainless steel, mirror stainless steel.
- Car ceiling** ZCL0-SP01 (hairline), ZCL0-SP02 (mirror).
- Handrail** Three-sided hairline stainless steel round handrail, Three-sided mirror stainless steel round handrail.
- Floor** PVC stone floor, parquet floor. (Parquet shown in figure: ZSC-016)

LEHY-III-HY05S (1050kg)
(1.0m/s, 1.6m/s, 1.75m/s, 2.0m/s) 

- Observation Plane** Facade semi-circular observation.
- External Decoration Material** Coated steel plate.
- External Decoration Lighting** Up&Down down light.
- Car Wall** Glass, hairline stainless steel, mirror stainless steel.
- Car door material** Hairline stainless steel, mirror stainless steel.
- Car ceiling** STD (coated steel plate, central round milky white transparent lighting 2 down lights at the entrance).
- Handrail** Hairline stainless steel round handrail, mirror stainless steel round handrail (only at observation plane).
- Floor** PVC stone floor.



LEHY-III-CX7S (900kg, 1050kg)
(1.0m/s, 1.6m/s, 1.75m/s, 2.0m/s) 

- Observation Plane** Facade cornering wide-view observation.
- External Decoration Material** Coated steel plate.
- External Decoration Lighting** Up&Down decoration mesh transparent lighting.
- Car Wall** Glass, hairline stainless steel, mirror stainless steel.
- Car door material** Hairline stainless steel, mirror stainless steel.
- Car ceiling** STD (lighting by round hole with semipermeable membrane layout).
- Handrail** Hairline stainless flat handrail (only at observation plane).
- Floor** PVC stone floor.



ZCL-DS12 (Alternative)*1*5

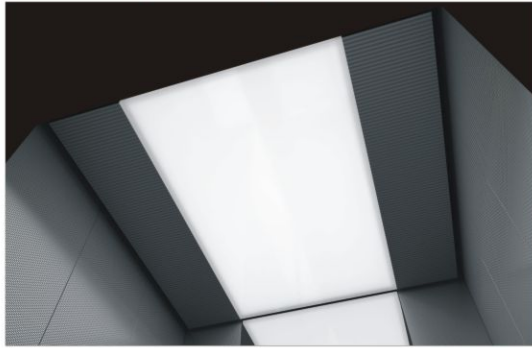

Lighting: Central direct lighting;
Material: Central inlet superior white transparent soft membrane, Hairline etched black-titanium-finish stainless steel at two sides.

ZCL-GS08 (Alternative)*1*5

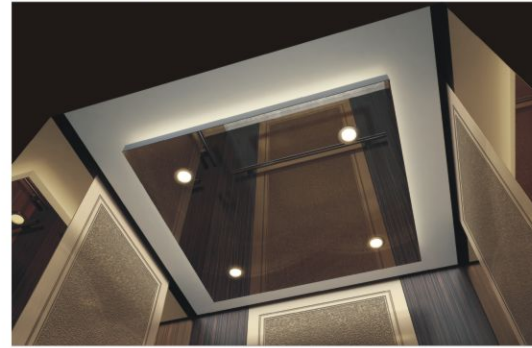

Lighting: Ambient floodlight, Central direct down light;
Material: Central mirror stainless steel, ambient coated steel plate (color number: Y033).

ZCL-GS16 (Alternative)*1*5

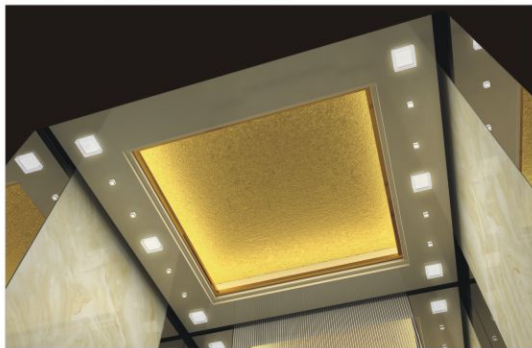

Lighting: Central main floodlight, auxiliary lighting at two sides
Material: Central floodlight gold foil, ambient coated steel plate (color number: Y033, if other colors are in need, select in accordance with the color panel palette of Shanghai Mitsubishi), acrylic crystal hanging pieces at two sides.

ZCL-DS13 (Alternative)*1*5



Lighting: central direct lighting; auxiliary lighting at two sides;
Material: arched milk white printed acrylic lighting boards, two-side acrylic crystal hanging pieces, stainless steel frame.

ZCL-GN04 (Alternative)*1*5

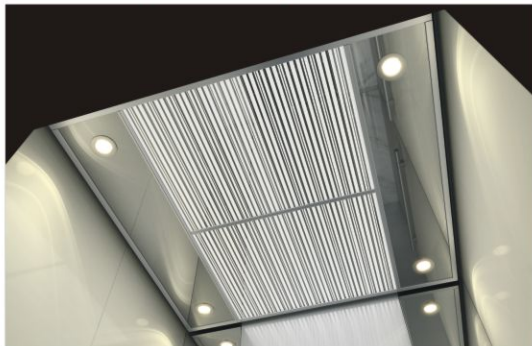

Lighting: central direct lighting; down light at two sides;
Material: central milky white printed acrylic lighting board, mirror acrylic boards at two sides, aluminum alloy frame.

ZCL-GN05 (Alternative)*1*5



Lighting: central direct lighting; down light at two sides;
Material: central milky white printed acrylic lighting board, golden mirror acrylic panel at two sides, aluminum alloy frame.

ZCL-GS06 (Alternative)*1*5

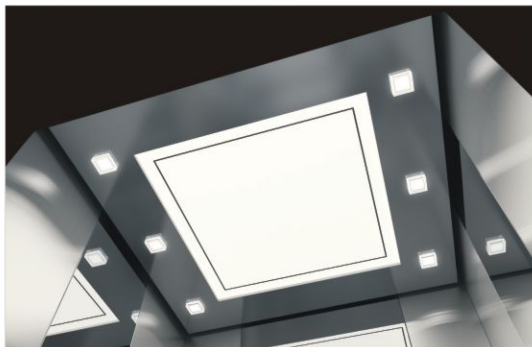

Lighting: central direct lighting; auxiliary lighting at two sides;
Material: central milky white printed acrylic lighting board, ambient metallic painting steel plate, acrylic crystal hanging pieces at two sides.

ZCL-GN02 (Alternative)*1*5



Lighting: central down light; lighting board at two sides;
Material: Hairline stainless steel ceiling.

Note: *1 Applicable to LEHY-III-S1, LEHY-III-S2, LEHY-MRL series.

*2 LEHY-III-SY06S.

*3 Applicable to LEHY-III-HY05S, LEHY-III-CX7S.

ZCL-GN03 (Alternative)*1*5

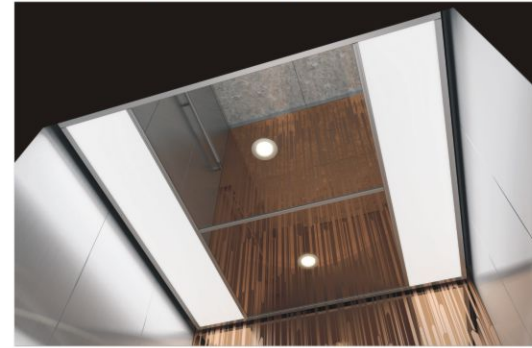

Lighting: central down light; lighting board at two sides;
Material: central mirror acrylic lighting board, milky white acrylic lighting boards at two sides, aluminum alloy frame.

ZCL-SS06 (Alternative)*1*5

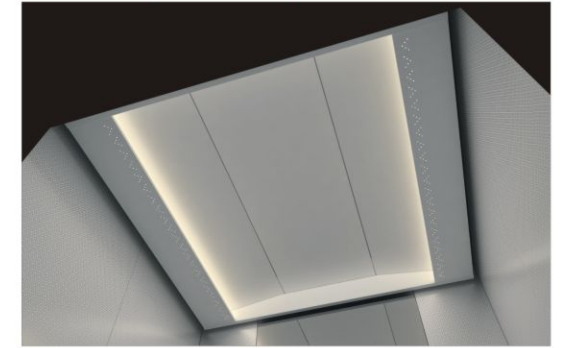

Lighting: warm floodlight lighting at two sides;
Material: Coated steel sheet ceiling plate (color code: Y033).

ZCL-SS08 (Alternative)*1*5



Lighting: Central direct lighting;
Material: central milky white printed acrylic lighting board, coating steel sheet at two sides (color code: Y033); if other colors are in need, select color in accordance with Shanghai color palette).

ZCL-SN03 (Alternative)*1*4

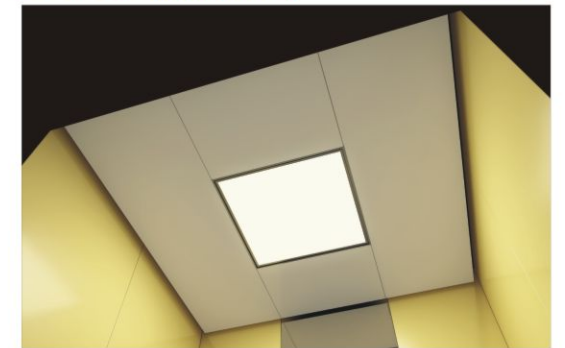

Lighting: central direct lighting;
Material: central milky white light guide plate, peripheral coating steel sheet ceiling (color code: Y033); if other colors are in need, select color in accordance with Shanghai color palette).

ZCL-SS07 (Alternative)*1*4

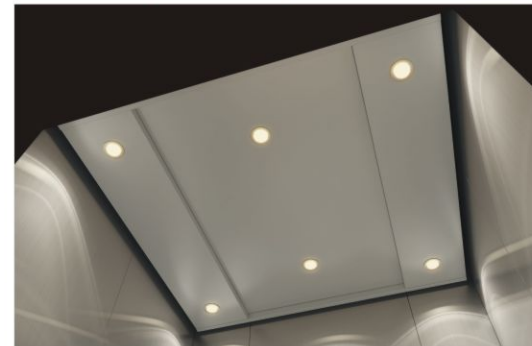

Lighting: down light direct lighting;
Material: Coated steel sheet ceiling (color code: Y033); if other colors are in need, select color in accordance with Shanghai color palette).

ZCL0-SP01*2



Car ceiling: Hairline stainless steel;
Lighting: Corner down light direct lighting;
Ventilation: Vent and cross flow fan at the entrance.

ZCL0-SP02*2

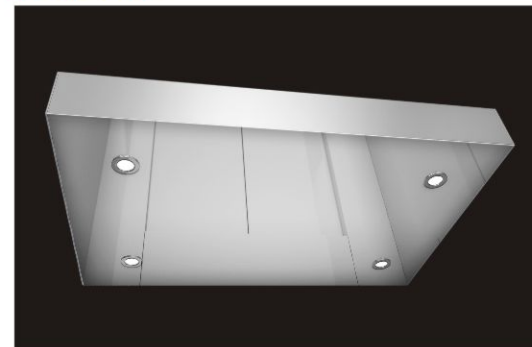

Car ceiling: Mirror stainless steel;
Lighting: Corner down light direct lighting;
Ventilation: Vent and cross flow fan at the entrance.

Note: *4 ceiling thickness 100mm.

*5 ceiling thickness 200mm.

ZCL-CN01 (Vacant car ceiling)*1*4

Ceiling decoration is provided by client.

ZCL-CN08 (Vacant car ceiling)*1*5

Ceiling decoration is provided by client.

STD*3

Note: All of the car ceilings use LED lighting.

Vent at car ceiling is provided at rear side of two sides.

Applicable to both deep and wide car cabin.

Able to provide safety window at car ceiling, contact salesman for detail.

The pictures are drawn by computer, which may be slightly different from the actual.

Front Wall Full-length/ Side Wall Operation Panel

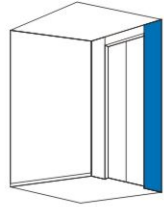

Put at the front wall when front wall width is $\geq 300\text{mm}$, and put at the side wall in the other cases.



ZCB■-T310*1*2 (Main) ZCB■-T360*1*2 (Auxiliary) (Provide when front wall width $\geq 300\text{mm}$) 8.4 inch TFT LCD display. Stainless steel faceplate. A11 button shown in the picture.	ZCB■-T710*1*2 (Main) ZCB■-T760*1*2 (Auxiliary) (Provide when front wall width $\geq 350\text{mm}$) 10.4 inch multimedia LCD display. Stainless steel faceplate. A23 button shown in the picture.	ZCB■-T410*1*2 (Main) ZCB■-T460*1*2 (Auxiliary) (Provide when front wall width $\geq 400\text{mm}$) 12.1 inch multimedia LCD display. Stainless steel faceplate. B02 button shown in the picture.	ZCB■-T810*1*2 (Main) ZCB■-T860*1*2 (Auxiliary) (Provide when front wall width $\geq 450\text{mm}$) 15.0 inch multimedia LCD display. Stainless steel faceplate. D01 button shown in the picture.
--	--	--	--

Note: *1 Applicable to LEHY-III-SY06S.
*2 Non-standard.
*3 Applicable to LEHY-III-S1, LEHY-III-S2, LEHY-III-HY05S, LEHY-III-SY06S, LEHY-III-CX7S.
*4 The difference of the appearance of ZCB■-F130 and ZCB■-F110: the button of the first floor is protruding and the frames of the two sides are black.

Front wall half-length operation panel

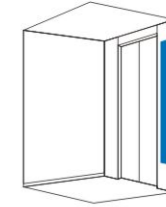

Provide when front wall width $\geq 250\text{mm}$.

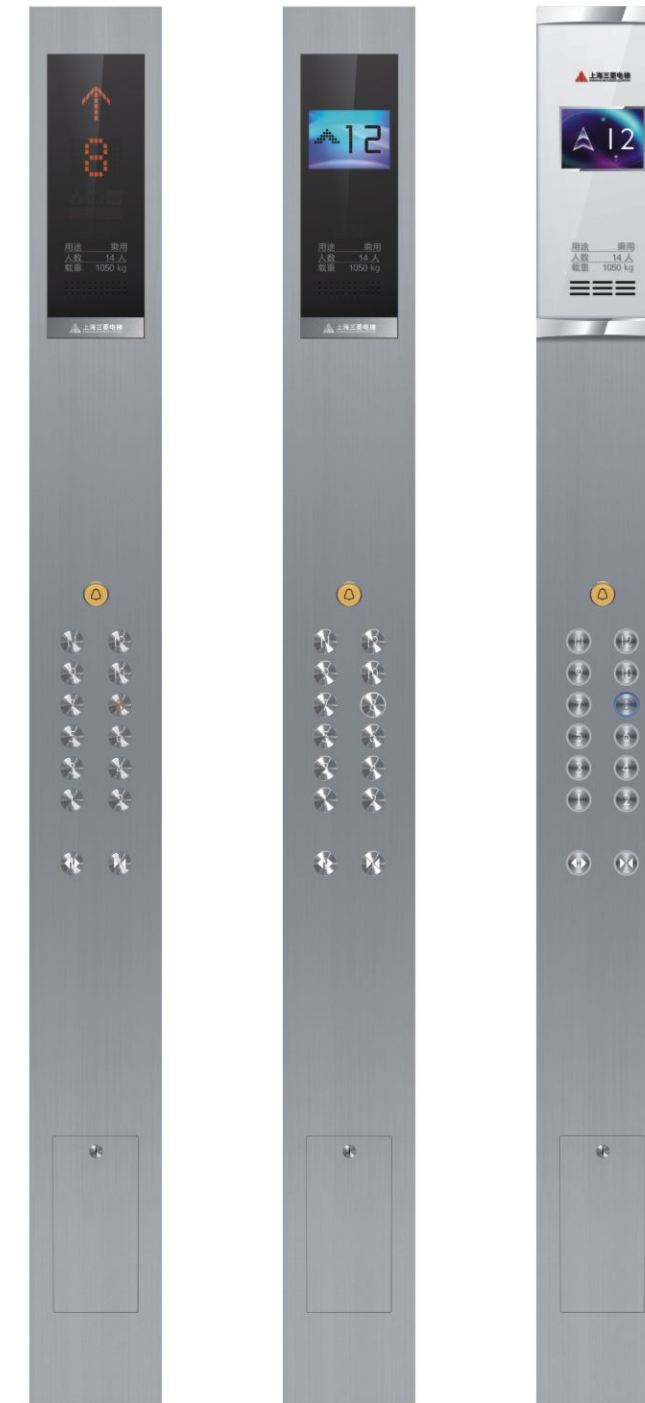

ZCB■-C110*3 (Main) ZCB■-C160*3 (Auxiliary) Stainless steel faceplate. Amber-colored LED display. Buttons are replaceable. A09 button shown in the picture.	ZCB■-C510*3 (Main) ZCB■-C560*3 (Auxiliary) Stainless steel plate. 5.7 inch color segment LCD display. Buttons are replaceable. A11 button shown in the picture.	ZCB■-C210*3 (Main) ZCB■-C260*3 (Auxiliary) Stainless steel plate. 5.7 inch TFT LCD display. Buttons are replaceable. A23 button shown in the picture.
---	--	--

Note:
Symbol ■ is button type, please select button and fill in from "page 24". When front wall half-length operation panel is provided with stops more than 28, it is recommended to select A01-A06 button. A04, A05, A06 are available for ZCB■-F130 and ZCB■-F110 (comply to GB/T24477).
LCD display see "Page 29".

Wheelchair operation panel

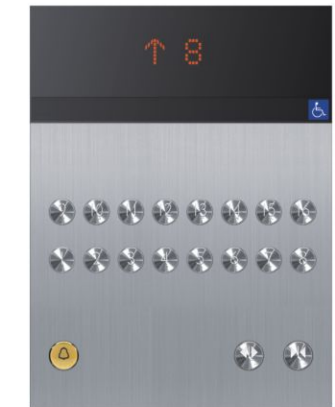
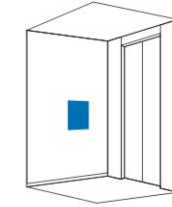

ZCB■-F110*2*3*4
(Main)
ZCB■-F160
(Auxiliary)

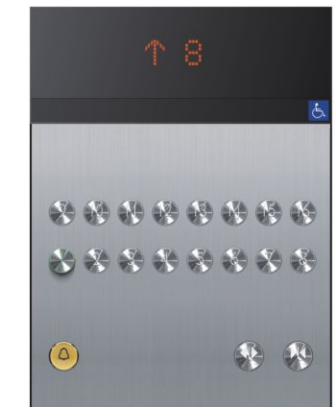

ZCB■-F130*2*3*4
(Main)
ZCB■-F180
(Auxiliary)

The pictures are drawn by computer, which may be slightly different from the actual.

LED dot-array display

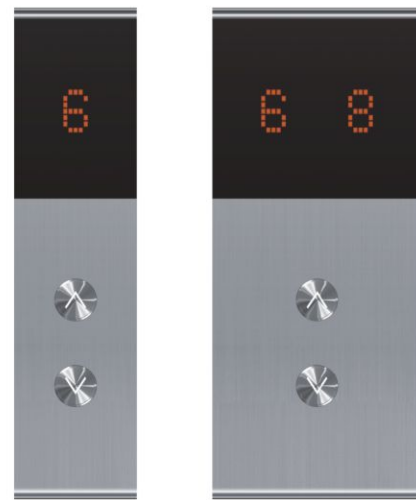

ZPI●-G110*1
Stainless steel faceplate.
Without bottom box.

ZPI●-G120*1
Stainless steel faceplate.
Without bottom box.

Button cross section without bottom box

These landing signal devices can be easily mounted on wall surface with no need to build in rear box after cutting the wall.

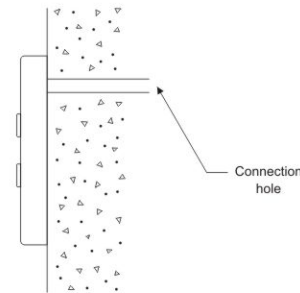

4.3 inch color segment LCD display



ZPI●-GB10*1
Stainless steel faceplate.
Without bottom box.

ZPI●-GB20*1
Stainless steel faceplate.
Without bottom box.

4.3 inch TFT LCD display



ZPI●-GA10*1
Stainless steel faceplate.
Without bottom box.

ZPI●-GA20*1
Stainless steel faceplate.
Without bottom box.

Note: *1 Applicable to 1 LEHY-III-S1, LEHY-III-S2, LEHY-III-HY05S, LEHY-III-SY06S, LEHY-III-CX7S.
*2 Applicable to LEHY-MRL.

Hall call

For obstacle-free solution, conform to GB/T24477



ZHBE-R110*2
ZHBE-R120*2
Hairline stainless steel faceplate.
Stainless steel round button.
Light up with orange light.



ZHB●-G010*1
(single elevator)
Without bottom box.
ZHB●-G020*1
(parallel connection)
Without bottom box.



ZHB●-H030*1
(single elevator)*3*4
Without bottom box.
ZHB●-H040*1
(parallel connection)*3*5
Without bottom box.



ZHB●-H041*1
(parallel connection)*3*6
Without bottom box.

Matching Scheme (For the disabled)

Correspond to single elevator, parallel connection respectively.

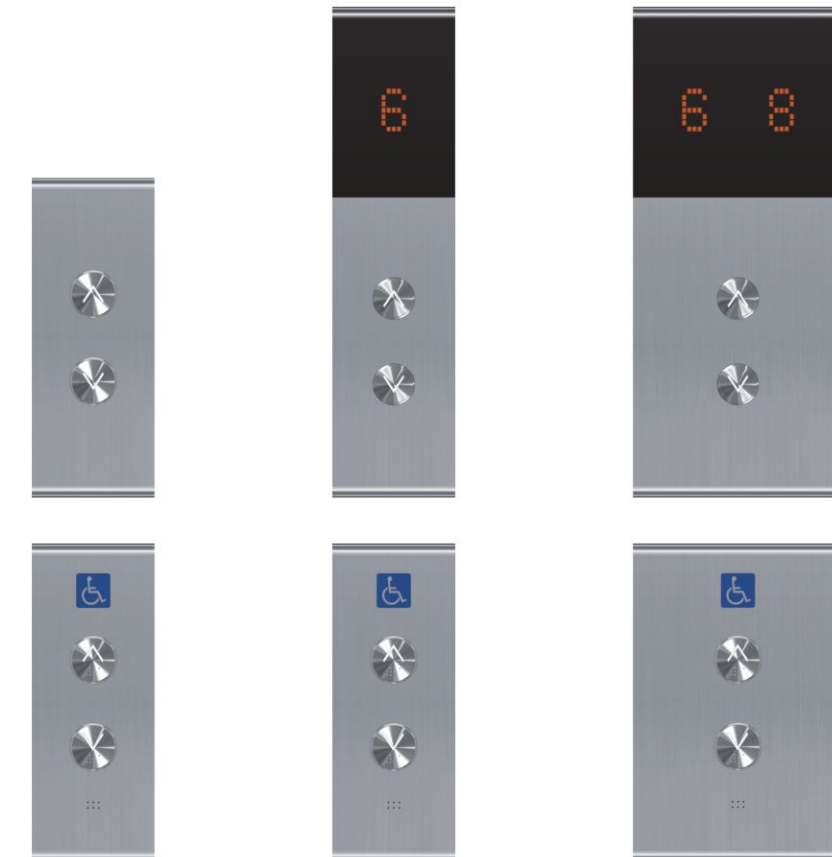

Note: *3 Alternative buttons are A14, A15, A16 (comply to GB/T24477), detail format shall refer to "Page 24".
*4 It needs to use together with ZHB●-G010 or ZPI●-GX10.
*5 It needs to use together with ZHB●-G020.
*6 It needs to use together with ZPI●-GX20.
Symbol ● is button type, please select buttons and fill in from "Page 24".
If it needs to provide bottom box, it is able to contact salesman to add bottom box in non-standard design, landing indicator with bottom box has the same appearance with ones without bottom box.

LED dot-array landing indicator



HID-A10

Built-in large landing indicator without faceplate. Applicable when door jamb is E-312.



HID-A20

Built-in large landing indicator. Applicable when door jamb isn't E-312, E-322.

LCD landing indicator



ZPIH-N301*1*2

Built-in landing indicator without faceplate. HD 8.4 inch TFT LCD display. Applicable when door jamb is E-322.



ZPIH-F301*1*2

Wall-mounted landing indicator. Transparent acrylic external frame. Matt chrome-coated panel. 8.4 inch TFT LCD display.

Landing direction light (no need to provide landing call buttons in "Page 24")



ZHLV-H021*3

Hairline/Mirror stainless steel faceplate. Mist white acrylic for lighting part.



ZHLV-H030*3

without faceplate. Mist white acrylic for lighting part. Needs to have precise reserved hole for wall decoration.



ZHLV-R061*3

Hairline/mirror stainless steel faceplate. Mist white acrylic for lighting part.



ZHLV-R070*3

without faceplate. Mist white acrylic for lighting part. Needs to have precise reserved hole for wall decoration.



ZHLV-R050*3

without faceplate. Mist white acrylic for lighting part. Needs to have precise reserved hole for wall decoration.



ZHLV-B031*3

Hairline/mirror stainless steel faceplate. Transparent acrylic for lighting part. (Laser engraving and sand blasting)



ZHLV-B040*3

Wall-mounted type without bottom box. Transparent acrylic for lighting part. (built-in mist white guide piece)

Landing direction light color guide



White



Warm white



Blue

Note: *1 Not applicable to LEHY-MRL series.

*2 LCD display shall see "Page 29".

*3 All of the direction lights are LED lights, which are energy-efficient and have longer lifetime. Each type of direction light has three luminous colors to choose: white, warm white, blue.

Basic buttons



A11

Diameter 35mm, mechanical inching button. Standby micro-luminous, stainless steel surface.

- A11 White Flat texture
- A12 Orange Flat texture
- A13 Blue Flat texture
- A14 White Braille with protruded texture
- A15 Orange Braille with protruded texture
- A16 Blue Braille with protruded texture



A01*4

Diameter 31mm, mechanical inching button. Standby micro-luminous, stainless steel surface.

- A01 White Flat texture
- A02 Orange Flat texture
- A03 Blue Flat texture
- A04 White Braille with protruded texture
- A05 Orange Braille with protruded texture
- A06 Blue Braille with protruded texture

Button effect



Alternative button



A09

Diameter 31mm, mechanical inching button, flat texture. Orange, round hairline stainless steel surface.



B02

Diameter 35mm, mechanical inching button. Orange, resin button cap, stainless button loop.



A23

Diameter 35mm, touching sense. Standby with white color, Luminous with blue color. Flat texture, CD-lined stainless steel surface.



D01

Square 35mm, mechanical inching button. White light, resin button cap.

Note: *4 When operation panel is provided with A01-A06, it is recommended to provide A11-A16 buttons for the call.

The pictures are drawn by computer, which may be slightly different from the actual.

Landing door and jamb

E-102 Narrow jamb



Landing material: Hairline stainless steel.
Jamb material: Hairline stainless steel.
Landing door type: Glass door.

E-302 Angled (10°) large jamb



Landing material: Hairline stainless steel.
Jamb material: Hairline stainless steel.
Landing door type: Standard door.

ELENESSA Machine-room-less Panoramic Elevator

Specification	Material	Remark
Jamb material	Coated steel plate, Metallic painted steel plate, Hairline stainless steel, Mirror stainless steel, Stainless steel with irregular-polished lines, Sand-pattern stainless steel, Hairline Titanium-finish stainless steel, Mirror Titanium-finish stainless steel, Titanium-finish stainless steel with irregular-polished lines, Sand-pattern Titanium-finish stainless steel.	When jamb type is E-102, E-302.
	Coated steel plate, Hairline stainless steel.	When jamb type is E-312.
Landing material	Coated stainless steel, Hairline stainless steel, Hairline Titanium-finish stainless steel, Mirror stainless steel, Mirror Titanium-finish stainless steel, Sand-pattern stainless steel, Sand-pattern Titanium-finish stainless steel, Stainless steel with irregular-polished lines, Titanium-finish stainless steel with irregular-polished lines.	
	Metallic painted steel plate, Laminated steel plate, Hairline etched stainless steel, Hairline etched Titanium-finish stainless steel, Mirror etched stainless steel, Mirror etched Titanium-finish stainless steel, Etched stainless steel with irregular-polished lines, Titanium-finish etched stainless steel with irregular-polished lines, Sand-pattern etched stainless steel, Sand-pattern etched Titanium-finish stainless steel.	Applicable to ELE-HY05S, ELE-NZ10S, ELE-NZ31S, Standard door
	Glass door.	Glass door

LEHY-MRL Machine-room-less Panoramic Elevator

Specification	Material	Remark
Jamb material	Coated stainless steel, Metallic painted steel plate, Hairline stainless steel, Mirror stainless steel, Stainless steel with irregular-polished lines, Sand-pattern stainless steel, Hairline Titanium-finish stainless steel, Mirror Titanium-finish stainless steel, Titanium-finish stainless steel with irregular-polished lines, Sand-pattern Titanium-finish stainless steel.	In case of center open door.
Landing material	Coated stainless steel, Laminated steel plate, Metallic painted steel plate, Hairline stainless steel, Hairline Titanium-finish stainless steel, Hairline etched stainless steel, Hairline etched Titanium-finish stainless steel, Mirror stainless steel, Mirror Titanium-finish stainless steel, Mirror etched stainless steel, Mirror etched Titanium-finish stainless steel, Sand-pattern stainless steel, Sand-pattern Titanium-finish stainless steel, Sand-pattern etched stainless steel, Sand-pattern etched Titanium-finish stainless steel, Stainless steel with irregular-polished lines, Titanium-finish stainless steel with irregular-polished lines, Etched stainless steel with irregular-polished lines, Titanium-finish etched stainless steel with irregular-polished lines.	In case of standard door and center open.
	Coated stainless steel, Hairline stainless steel, Hairline Titanium-finish stainless steel, Mirror stainless steel, Mirror Titanium-finish stainless steel, Sand-pattern stainless steel, Sand-pattern Titanium-finish stainless steel, Stainless steel with irregular-polished lines, Titanium-finish stainless steel with irregular-polished lines.	In case of glass door and center open.

E-312 Curtain angled (10°) jamb



Landing indicator: HID-A10.
Landing material: Hairline etched stainless steel (Color No: ZHY-006).
Jamb material: Hairline stainless steel.

E-322 Oblique curtain angled (10°) jamb



Landing material: ZPIH-L610D.
Jamb material: Mirror etched Titanium-finish stainless steel (ZHY-010 + ZDT-002).
Landing door type: Mirror Titanium-finish stainless steel (ZDT-002).

LEHY-III Machine-room-less Panoramic Elevator

Specification	Material	Remark
Jamb material	Coated stainless steel, Hairline stainless steel, Mirror stainless steel, Hairline Titanium-finish stainless steel, Mirror Titanium-finish stainless steel.	When door jamb is E102/E302.
	Coated stainless steel, Hairline stainless steel, Mirror stainless steel.	When door jamb is E312/E322.
Landing material	Coated stainless steel, Hairline stainless steel, Hairline etched stainless steel, Mirror stainless steel, Mirror etched stainless steel, Hairline Titanium-finish stainless steel, Mirror Titanium-finish stainless steel, Hairline etched Titanium-finish stainless steel, Mirror etched Titanium-finish stainless steel.	Standard door.
	Coated stainless steel, Hairline stainless steel, Mirror stainless steel, Hairline Titanium-finish stainless steel, Mirror Titanium-finish stainless steel.	Glass door.

Landing door type	Type	Applicable elevator
Standard door		LEHY-III series panoramic elevator
Glass door	ZPKG-150A	LEHY-III-SY06S*1

Note: *1 It needs to have non-standard confirmation for LEHY-III series panoramic elevator.

The pictures are drawn by computer, which may be slightly different from the actual.

Handrail type

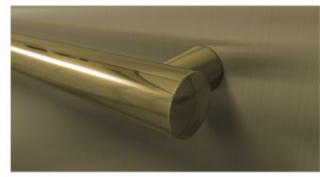

YH-59G*1

Mirror Titanium-finish stainless steel (Golden).

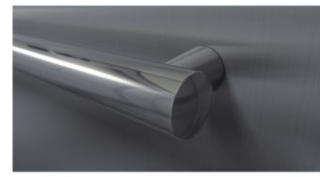

YH-59M*1

Mirror stainless steel.

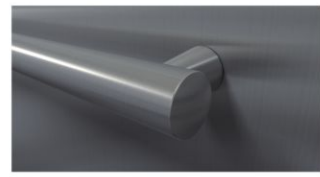

YH-59S*1

Hairline stainless steel.



YH-57S*1

Hairline stainless steel.

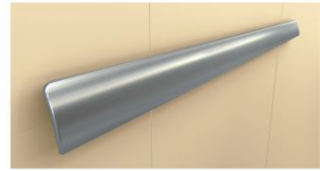

ZYH-RH01*2

Stainless steel leaning handrail.



ZYH-RH02*2

Stainless steel flat handrail.

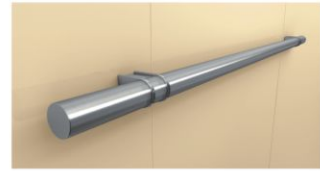

ZYH-SH01*2

Stainless steel round handrail.

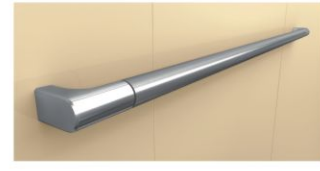

ZYH-FH10*2

Stainless steel round handrail.

Floor material

For decoration needs of different grades, there 8 parquet designs consisting of parquet marble or parquet PVC floor. And PVC stone floor with single color is also available, select color number according to decoration color panel of Shanghai Mitsubishi.

Parquet marble



ZSC-001*2



ZSC-002*2

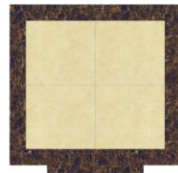

ZSC-011*2



ZSC-012*2



ZSC-013*2

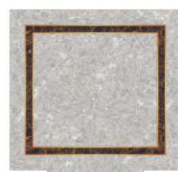

ZSC-014*2

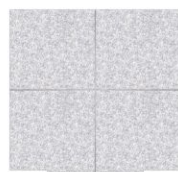

ZSC-015*2



ZSC-016*2

Parquet PVC stone



ZPH-027*2

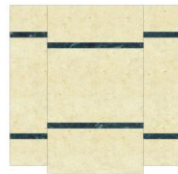

ZPH-030*2



ZPH-028*2

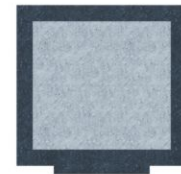

ZPH-023*2



ZPH-026*2

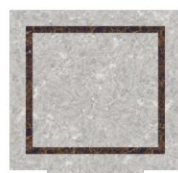

ZPH-029*2



ZPH-031*2

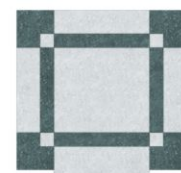

ZPH-014*2

Note: *1 Applicable to ELENESSA series.
*2 Applicable to LEHY-MRL/LEHY-III series.

Painting (add new pure and fresh color sample)

see Shanghai Mitsubishi decoration color panel for more painting color.



ZY-014

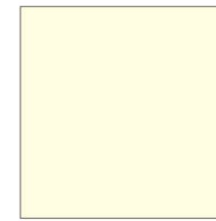

ZY-015

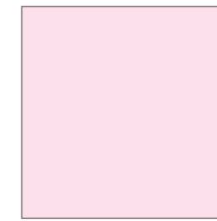

ZY-016



ZYM-001

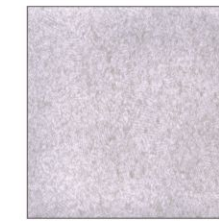

ZYM-007

Laminated steel plate

see Shanghai Mitsubishi decoration color panel for more types of laminated steel plate.

Etched figure

see Shanghai Mitsubishi decoration color panel for more etched figures.

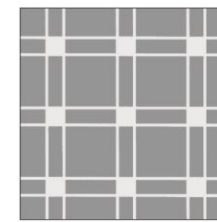

ZHY-004



ZHY-006



ZHY-008

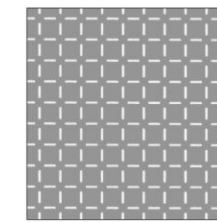

ZHY-015

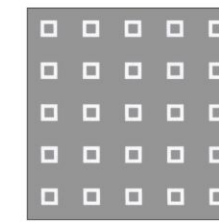

ZHY-016

Car material configuration table (available: ●)

Material	Glass	Coated stainless steel	Laminated steel plate	Metallic painted steel plate	Hairline stainless steel	Hairline Titanium-finish stainless steel	Hairline etched stainless steel	Hairline etched Titanium-finish stainless steel	Mirror stainless steel	Mirror Titanium-finish stainless steel	Mirror etched stainless steel	Mirror etched Titanium-finish stainless steel	Sand-pattern stainless steel	Sand-pattern Titanium-finish stainless steel	Sand-pattern etched stainless steel	Sand-pattern etched Titanium-finish stainless steel	Stainless steel with irregular polished lines	Titanium-finish stainless steel with irregular polished lines	Etched stainless steel with irregular polished lines	Titanium-finish etched stainless steel with irregular polished lines		
																					Car wall	Front wall
ELENESSA Series	HY05S	Car wall	●																			
		Front wall																				
		Car doors																				
		standard doors																				
LEHY-MRL Series	NZ10S	Car wall	●																			
		Front wall																				
		Car doors																				
		standard doors																				
LEHY-MRL Series	NZ31S	Car wall	●																			
		Front wall																				
		Car doors																				
		standard doors																				

Colored segment LCD display

Patented LCD technique: Innovative interface, Full View, High contrast ratio.



4.3 inch LCD screen (for landing indicator)



5.7 inch LCD screen (for landing indicator)

TFT LCD Display

A new generation of LCD uses advanced hardware driver circuit with the more delicate LCD screen and features a new interface design, giving new life to ordinary LCD, more lively, more vivid, and more enjoyable. Typical four-style interface designed to meet the needs of different styles and decorating the car.

Horizontal elevator operation indicator *1



Dazzle purple - Standard



Refreshing green - Residential



Elegant brown - Hotel



Stylish blue - Business

Vertical elevator operation indicator *2



Dazzle purple - Standard



Refreshing green - Residential



Elegant brown - Hotel



Stylish blue - Business

Note: *1 Used for car operation panel, landing TFT LCD screen 5.7 inch; for landing TFT LCD screen 8.4 inch.
*2 For car operation panel TFT LCD screen 8.4 inch; for landing TFT LCD screen 4.3 inch.
Need to designate one interface in elevator order.

Multimedia Information Display System (EMIDS)

With a more powerful processing system and more delicate LCD screen, it is updated on the basis of hardware and develops a variety of new design interface. Realize the elevator floor signal indicative of simultaneously excellent displaying of the multimedia information, in a small elevator space for the owners to do advertising, and also for the passengers to have a more pleasant riding experience.



Classic A



Classic B



Full Screen

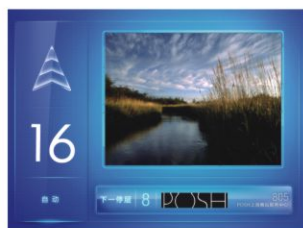

Forecast Floor A



Forecast Floor B

Note: * All of the 5 types of interface are contained in the device, and the interface can be updated at the field with software in host computer.

Basic specification LEHY-MRL NZ10S/NZ11S/NZ31S

Item	Specification Content			Remark
Rated speed (m/s)	1.0	1.6	1.75	
	630	630	630	
Rated load (kg)	800	800	800	
	1050	1050	1050	
Stop	2-18	2-22	2-22	Except NZ31S.
	2-16	2-16	2-16	Applicable to NZ31S.
Traveling Height TR (m)	2.6-55	5.5-60	6.4-60	Except NZ31S.
	2.6-40	5.5-40	6.4-40	Applicable to NZ31S.
Operation method	1C-2BC, 2C-SM21, 2C-ITS21, 3C-ITS-21, 4C-ITS-21			
Control method	VFG-L			
Specification code	P-08			
	P-10			
	P14W, P14D			
Door open method	Center open			
Door open type	1D1G			
Dynamic power	380V50Hz 3-phase 5-line mode			
Lighting power	220V50Hz single phase			
Min. Floor Height (mm)	≥2800			In case of concrete nosing provided by client
	≥2600			In case of steel nosing provided by the seller.
CWT position	Side placed			
CWT safety gear	Without, With			
Floor Indication Scope	B1, B2, B3, B4, B5, B, G, M, -1, -2, -3, -4, -5, 1, 2, 3, 4, 5, 6, 7, 8, 9, 10, 11, 12, 13, 14, 15, 16, 17, 18, 19, 20, 21, 22, 23, 24, 25, 26, 27, 28, 29, 30, 31, 32, 33, 34, 35, 36, 37, 38, 39, 40, 41, 42, 43, 44, 45, 46, 47, 48, 3A, 5A, 12A, 13A, 15A, 17A, 23A, 12B			

Basic specification LEHY series S1/S2/HY05S/CX7S/SY06S

Item	Specification Content					Remark
Rated speed (m/s)	1.0	1.6	1.75	2.0	2.5	
	800	800	800	800	800	Applicable to S1, S2.
	900	900	900	900	900	Applicable to S1. Applicable to CX7S: 1m/s, 1.6m/s, 1.75m/s, 2m/s.
	1050	1050	1050	1050	1050	Applicable to S1, S2. Applicable to HY05S, CX7S: 1m/s, 1.6m/s, 1.75m/s, 2m/s. Applicable to SY06S: 1m/s, 1.6m/s, 1.75m/s.
	1200	1200	1200	1200	1200	Applicable to S1, S2. Applicable to SY06S: 1m/s, 1.6m/s, 1.75m/s.
Rated load (kg)	1350	1350	1350	1350	1350	Applicable to S1, S2. Applicable to SY06S: 1m/s, 1.6m/s, 1.75m/s.
	1600	1600	1600			Applicable to SY06S.
Stop	2-20	2-28	2-28	2-28	2-28	
Traveling height TR (m)	2.6-55	5.5-80	6.4-80	8-80	11-80	
Operation method	1C-2BC, 2C-SM21, 3C-ITS-21, 4C-ITS-21					
Control method	VFG-L					
Car type	Wide car					
Door open method	Center open					
Door open type	1D1G					
Dynamic power	380V50Hz 3-phase 5-line mode					
Lighting power	220V50Hz single phase					
Min. Floor Height (mm)	2800					In case of concrete nosing ≥2800, it will be provided by client. In case of steel nosing ≥2600, it will be provided by the seller.
CWT position	Side placed					
CWT safety gear	Without					
Floor Indication Scope	B1, B2, B3, B4, B5, B, G, M, -1, -2, -3, -4, -5, 1, 2, 3, 4, 5, 6, 7, 8, 9, 10, 11, 12, 13, 14, 15, 16, 17, 18, 19, 20, 21, 22, 23, 24, 25, 26, 27, 28, 29, 30, 31, 32, 33, 34, 35, 36, 37, 38, 39, 40, 41, 42, 43, 44, 45, 46, 47, 48, 3A, 5A, 12A, 13A, 15A, 17A, 23A, 12B					

Basic specification ELENESSA HY05S/NZ10S/NZ31S/N32S

Item	Specification Content			Remark
Rated speed (m/s)	1.0	1.6	1.75	
	630	630	630	Only applicable to NZ10S.
	825	825	825	Applicable to HY05S, NZ10S, NZ31S.
Rated load (kg)	1050	1050	1050	Applicable to HY05S, NZ10S, NZ31S.
	1200	1200	1200	Only applicable to NZ32S.
	1350	1350	1350	Only applicable to NZ32S.
	2-22	2-22	2-22	Only applicable to HY05S.
	2-22	2-30	2-30	Applicable to NZ10S, NZ31S.
Stop	2-18	2-18	2-18	Only applicable to NZ32S.
	3.4-60	7.3-60	7.3-60	Applicable to HY05S, NZ32S.
Traveling height TR (m)	3.4-60	7.3-80	7.3-80	Applicable to NZ10S, applicable to NZ31S: 825kg or 1050kg and 1D1G.
	3.4-40	7.3-40	7.3-40	Only applicable to NZ31S: 1050kg and 1D2G.
	2100	2100	2100	Applicable to HY05S: Car net height is 2300mm. Applicable to NZ10S, NZ31S: Car net height is 2200mm.
Door open height HH(mm)	2100, 2200	2100, 2200	2100, 2200	Applicable to NZ10S, NZ31S, NZ32S: Car net height is 2300mm.
	2100, 2200, 2300	2100, 2200, 2300	2100, 2200, 2300	Applicable to NZ10S, NZ31S, NZ32S: Car net height is 2400mm.
	2100, 2200, 2300, 2400	2100, 2200, 2300, 2400	2100, 2200, 2300, 2400	Applicable to NZ10S, NZ31S: Car net height is 2500mm.
	2300	2300	2300	Only applicable to HY05S.
Car Net Height HL(mm)	2200, 2300, 2400, 2500	2200, 2300, 2400, 2500	2200, 2300, 2400, 2500	Applicable to NZ10S, NZ31S: Standard car ceiling (S00, S200, L200, L200S, L210, L210S).
	2200, 2300, 2400	2200, 2300, 2400	2200, 2300, 2400	Applicable to NZ10S, NZ31S: Standard car ceiling (S300, N120, N130, N140, N300, N300S, L310).
	2200, 2300	2200, 2300	2200, 2300	Applicable to NZ10S, NZ31S: Standard car ceiling (L400).
	2300, 2400	2300, 2400	2300, 2400	Applicable to NZ32S: Standard car ceiling (S00, S200, L200, L200S, L210, L210S, S300, N120, N130, N140, N300, N300S, L310).
Operation method	1C-2BC, 2C-2BC, 2C-AI-22, 3C-AI-22, 4C-AI-22			Operation method is 2C-2BC only for NZ31S single door open.
Roping Ratio	2:1			
Control method	VFGLC			
Door system	LV0K-L2N-CO			
	LV1K-L3N-2S			Only applicable to NZ10S.
Door open method	Center open			
	Side open			Only applicable to NZ10S.
Door open direction	Left open, right open			Only applicable to NZ10S and door open method is side open.
Door open type	1D1G			Single open.
	1D2G			Only applicable to NZ31S: Not parallel connection and 825kg, 1050kg and BB≥1400.
	2D2G			Only applicable to NZ31S: Non-standard.
Dynamic power	380V50Hz 3-phase 5-line mode			
Lighting power	220V50Hz single phase			
CWT position	Side placed			
CWT safety gear	Without With			
Floor Indication Scope	B1, B2, B3, B4, B5, B, G, M, 0, -1, -2, -3, -4, -5, 1, 2, 3, 4, 5, 6, 7, 8, 9, 10, 11, 12, 13, 14, 15, 16, 17, 18, 19, 20, 21, 22, 23, 24, 25, 26, 27, 28, 29, 30, 31, 32, 33, 34, 35, 36, 37, 38, 39, 40, 41, 42, 43, 44, 45, 46, 47, 48, 3A, 5A, 12A, 13A, 15A, 17A, 23A, 12B			

Basic specification ELENESSA HY05S/NZ10S/NZ31S/N32S

Item	Specification Content	Remark
Min. Floor Height (mm)	≥2800	Concrete nosing (by client) and HH=2100 and center open door (without car door lock).
	≥2900	Applicable to NZ10S, NZ31S, NZ32S: concrete nosing (by client) and HH=2200 and center open (Without car door lock).
	≥3000	Applicable to NZ10S, NZ31S, NZ32S: concrete nosing (by client) And HH=2300 and center open (without car door lock).
	≥3100	Applicable to NZ10S, NZ31S: concrete nosing (by client) And HH=2400 and center open (without car door lock).
	≥2600	Steel nosing (by client) and HH=2100 and center open (without car door lock).
	≥2700	Applicable to NZ10S, NZ31S, NZ32S: steel nosing (by the seller) And HH=2200 and center open (without car door lock).
	≥2800	Applicable to NZ10S, NZ31S, NZ32S: steel nosing (by the seller) And HH=2300 and center open (without car door lock).
	≥2900	Applicable to NZ10S, NZ31S: steel nosing (by the seller) And HH=2400 and center open (without car door lock).
	≥3100	Applicable to NZ10S: HH=2100 and side open door (standard car door lock).
	≥3200	Applicable to NZ10S: HH=2200 and side open door (standard car door lock).
	≥3300	Applicable to NZ10S: HH=2300 and side open door (standard car door lock).
≥3400	Applicable to NZ10S: HH=2400 and side open door (standard car door lock).	

Note: Please contact our business department if the specification isn't in above scope.



SAFE AND SECURE CREATE HARMONY

Technology Changes Life
 Scientific Intelligence Leads the Future,
 Shanghai Mitsubishi Elevator will be there for you always.

ELENESSA DESIGN
 LEHY-MRL/LEHY-III DESIGN
 GENERAL DESIGN
 SPECIFICATION
 SAFETY AND SECURE

