

Shanghai Mitsubishi Elevator Co.,Ltd.

Address: No.811 Jiangchuan Road.Minhang,Shanghai,China

Tel: +86-21-24083030/64303030

Fax: +86-21-24083088

Post: 200245

Overseas Business

Tel: +86-21-24083482

Fax: +86-21-24083488

E-mail: overseasbiz@smec-cn.com

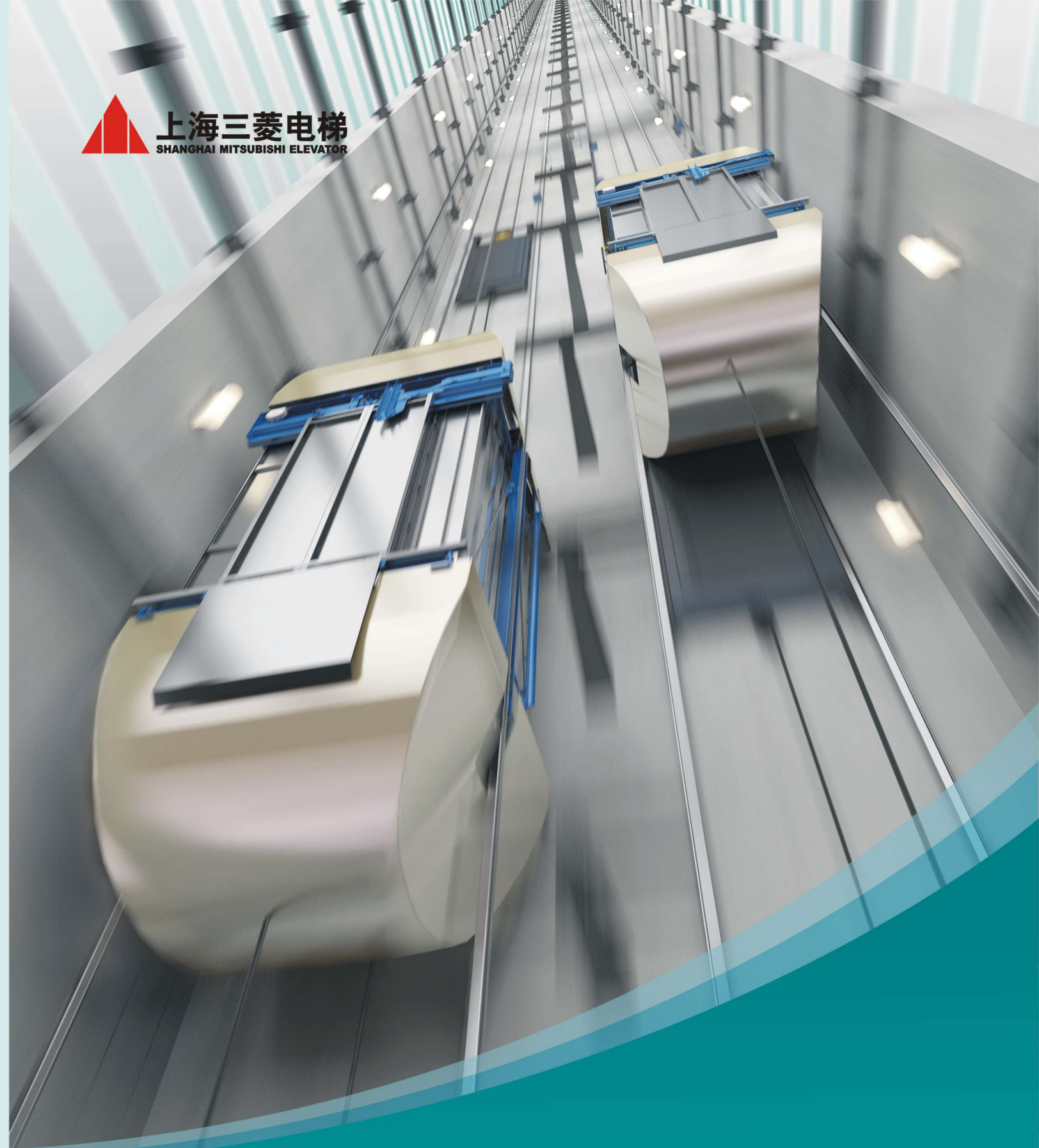

www.smec-cn.com



Specifications subject to change without notice
Printed in Dec.2015.11

High Speed LEHY Highly Comfortable

LEHY Series Permanent Magnet Synchronous Medium
and High-speed Passenger Elevators

LEHY-M-II/LEHY-H

LEHY Series Medium And High-speed Passenger Elevators

LEHY-M-II/LEHY-H Series Passenger Elevator

Perfect smooth and comfortable Super fast experience

Shanghai Mitsubishi LEHY-M-II / LEHY-H are high-grade elevators specifically designed for commercial buildings, shopping malls, hotels, high-end residential properties. Integrated with Mitsubishi VVVF (VVVF) drive control technology, energy feedback technology with dual PWM control, data network control technology, and many other advantages of Mitsubishi technology, it is undoubtedly is the classics of elevator in the world.

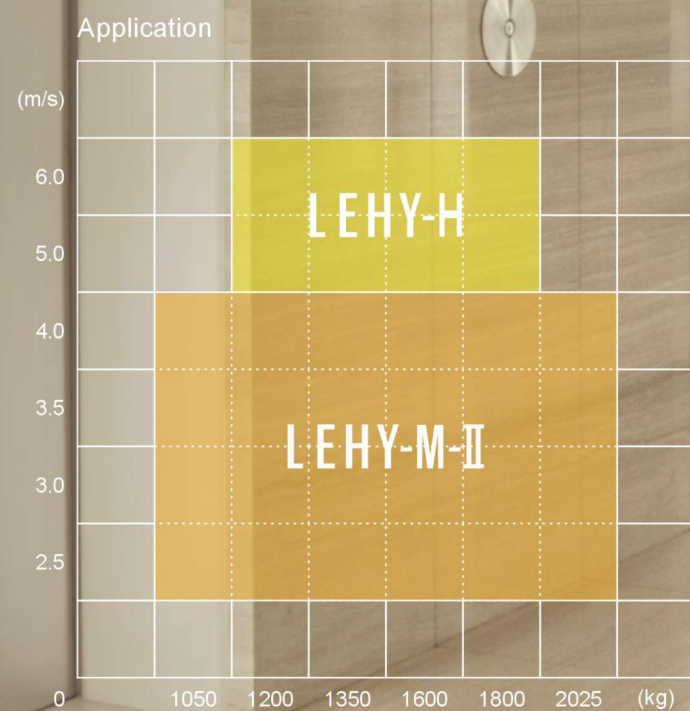

4 major Technical characteristics	P.03	SUMMARY
7 technological innovations	P.05	
Humanized design of decoration components	P.08	
Deluxe Holistic Design of Car Compartment	P.09	DESIGN
Car Top Design	P.12	
Car Operating Panel	P.13	
Landing monitor and Landing Call Button	P.17	
New Generation LCD	P.18	
Lobby Design	P.19	
Material Correspondence	P.21	
Function Table	P.22	FEATURES
Basic Specification	P.25	SPECIFICATION
Civil Construction List	P.27	CIVIL ENGINEERING
Safety and Security Create Harmony	P.29	SAFE AND SECURE

Traction Machine Brand New Upgrade

Shanghai Mitsubishi LEHY Medium and high-speed elevator (LEHY-M-II / LEHY-H) adopts efficient drive system and digital control, to improve the speed of LEHY series elevator to 6.0m/s.

A new generation of high-performance permanent magnet synchronous motor drive gearless machine, applies the brand new large size and low noise disc brake technology, which in the secure and sufficient output of braking torque, dramatically reduces brake noise, and has safer, more reliable and durable characteristics. High sensitivity of weighing sensor applications enables real-time accurate detection on elevator loads. Combined with pre-start torque compensation for the weigh, it eliminates the discomfort in starting, running and stop, and ensure comfort during the entire running of the elevator running at high speed.

LEHY-M-II applies heat pipe cooling system, which improves the cooling efficiency, and reduces the heat dissipation area.

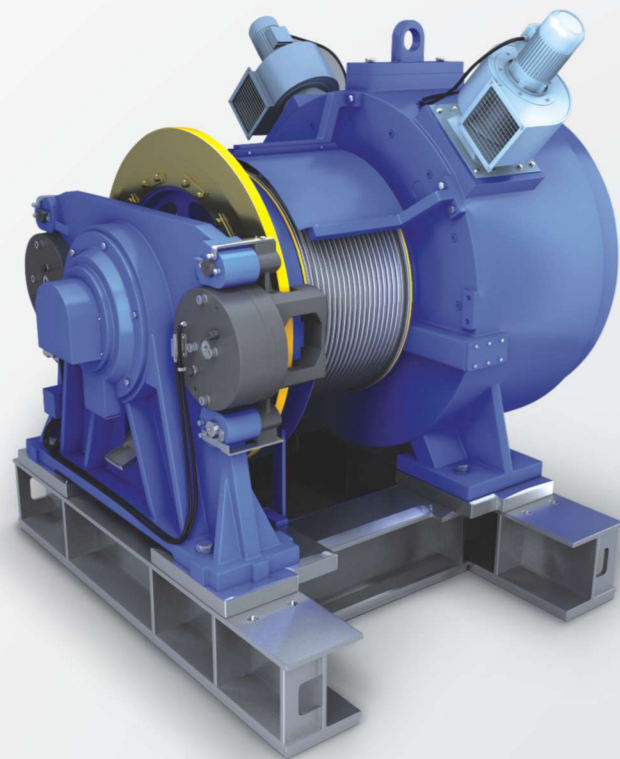

▲ LEHY-H permanent magnet synchronous gearless traction machine (LEHY-H high-speed elevator PM traction machine)

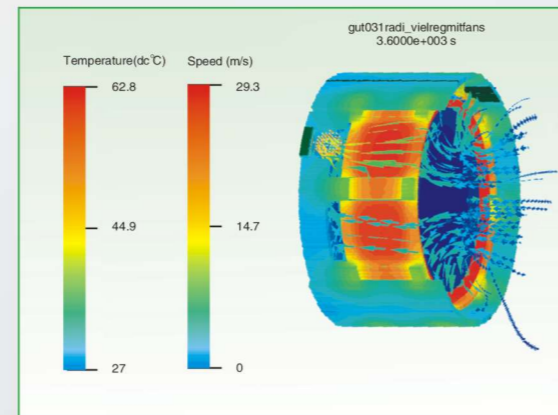

▲ LEHY Series Traction Machine Temperature Field Image



▶ LEHY-M-II permanent magnet synchronous gearless traction machine (LEHY-M-II high-speed elevator PM traction machine)

Mute Band Brake Control Technology

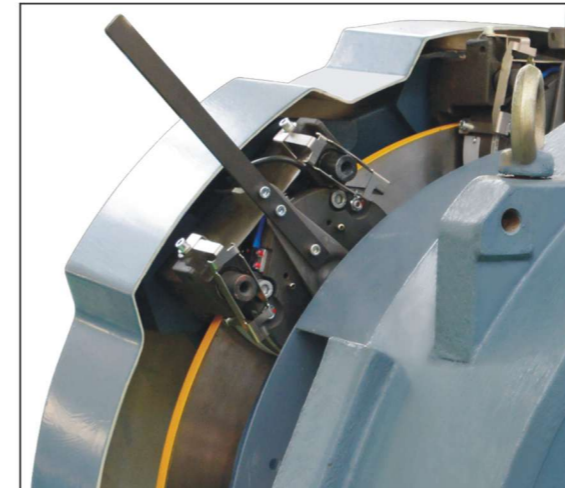

Compared to traditional open-loop control voltage, it adopts a more accurate closed-loop control mode, which can precisely control the band brake operation speed and brake torque at each phase, significantly reducing operation noise when the brake is working, and improving the ride comfort.

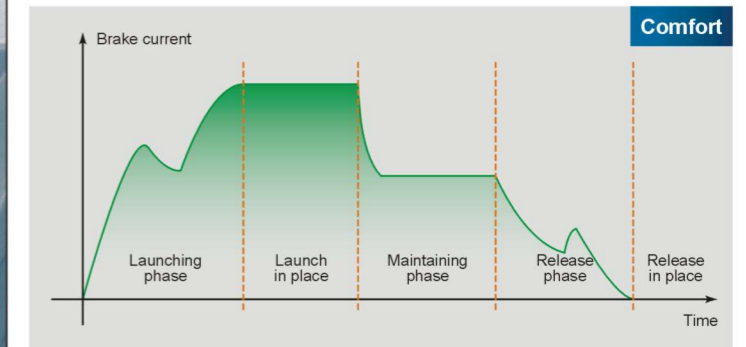

The Latest Generation of High-power Module

The industry's first application of the sixth generation of high-power module system. Multiple fast protection circuit can better protect the power module, to further improve the reliability of the drive system. Meanwhile, the drive power module and power module line control circuit are connected to further enhance the anti-jamming capability.

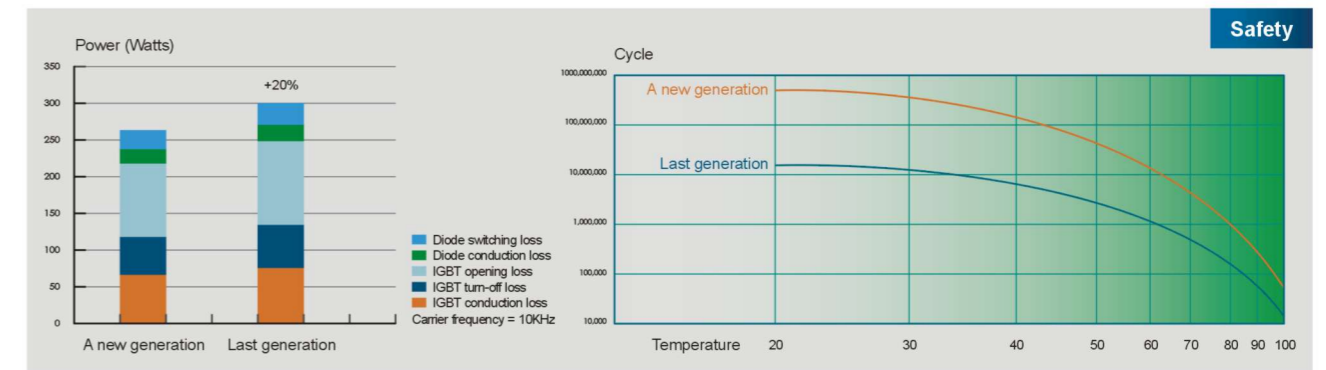

High Performance and Intelligent CPU Control System

Adopt 32-bit CPU, 32-bit high speed digital signal controller (DSC) and large scale field-programmable gate array (FPGA) and other high-performance chip, apply international advanced SMT (surface mount) technology, the digital control and motor drive, the control performance and reliability of the system is further improved, which completely ensures the comfort and safety of the elevator.

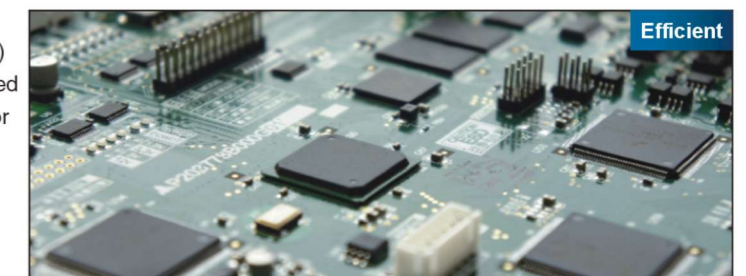

Application of Digital Technology

Shanghai Mitsubishi Elevator has enhanced in recent years in the field of product development and research efforts of the application of digital technology and research, for the structure, vibration, noise, transmission and control and other key technologies in the research and development of high-speed elevator, it has carried out the comprehensive system level, component level control simulation, multi-body dynamics simulation and stress field, flow field, thermal field, sound field, electromagnetic field coupling of single or multi-field simulation, to enhance the development capacity and level of Mitsubishi Medium and high-speed elevator product through the application of digital product development platform and modern test platform.

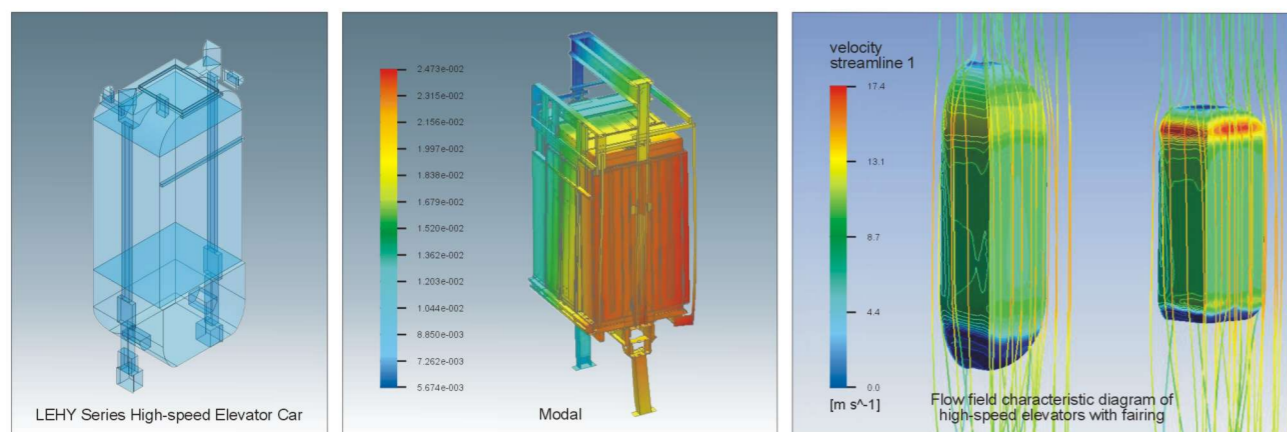

Energy Feedback Technology (Standard Configuration)

Based on dual PWM control high-energy saving energy feedback technology, it can feedback the originally consumed regenerative energy by resistance to the grid without pollution, and it can save more than 30% of the energy than the average ordinary VVVF elevator, fully meeting the relevant national power quality standards.

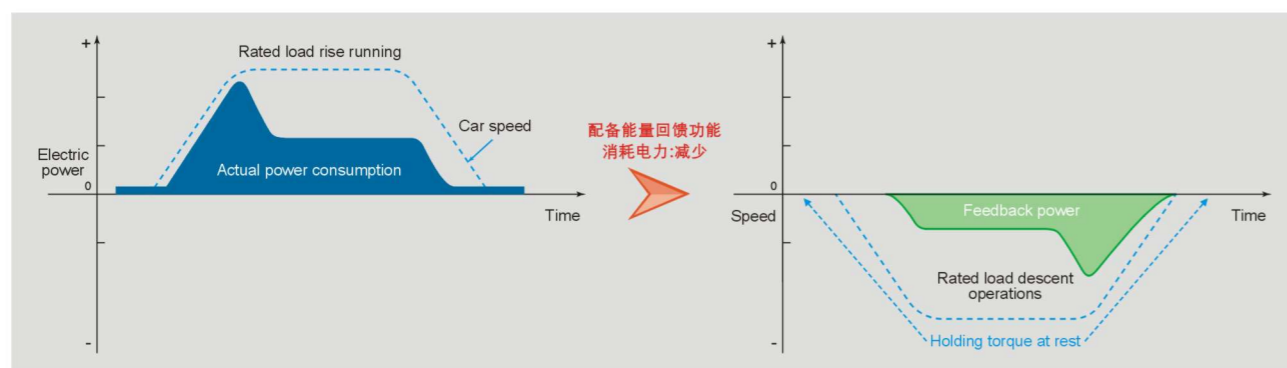

LIMAX Elevator Shaft Safety System



Adopt the German ELGO company LIMAX shaft safety system, allowing the use of the Stroke reduction buffer, which has achieved the current world highest elevator Safety Integrity Level SIL3. Make sure the elevator in the shaft speed security control issue (especially in the upper and lower terminals).

Data Network Control Technology

Based on CANBUS (field bus) data network control technology, with high speed communications, data volume, and independent microprocessors are used in the elevator car command controller, car inner floor indicator, door controller, each landing button and floor display and other subsystem. The communication between the various subsystems just requires a few signal lines, which can greatly improve the reliability, electromagnetic interference and flexibility of the system, reducing maintenance costs.

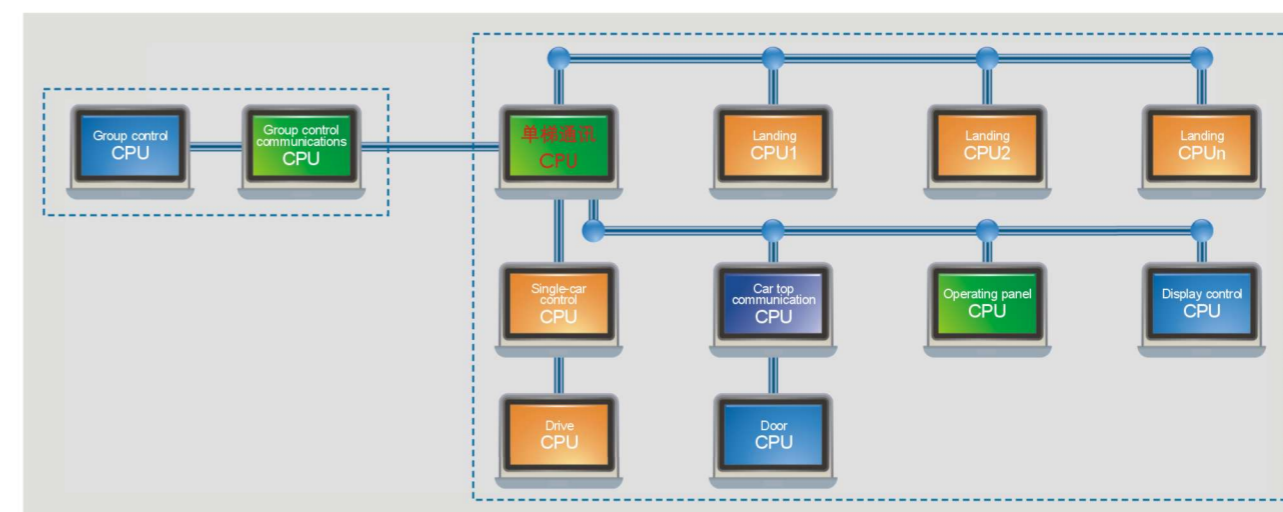

AC Variable Voltage Variable Frequency Speed Control Technology, Full Digital Control Technology

Adhering to the concept of laying a solid foundation for slow release, keep the latest technology and variable voltage variable frequency drive device for an elevator, Shanghai Mitsubishi VVVF control technology is developing towards high performance, high reliability, digitization and miniaturization direction rapidly. Application of space vector control technology (SVPWM) achieves elevator speed, the first to apply the sixth generation of the international latest power modules, 32 high-speed digital signal controller (DSC) and large-scale integrated circuits and other advanced electrical components, enables the elevator in full accordance with the best speed curve to accurately adjust the motor speed, the curve running along the optimized desired speed according to modern ergonomic principles designed to achieve a full digital control and motor drive in the true sense, making the elevator run smoothly, safely and efficiently.

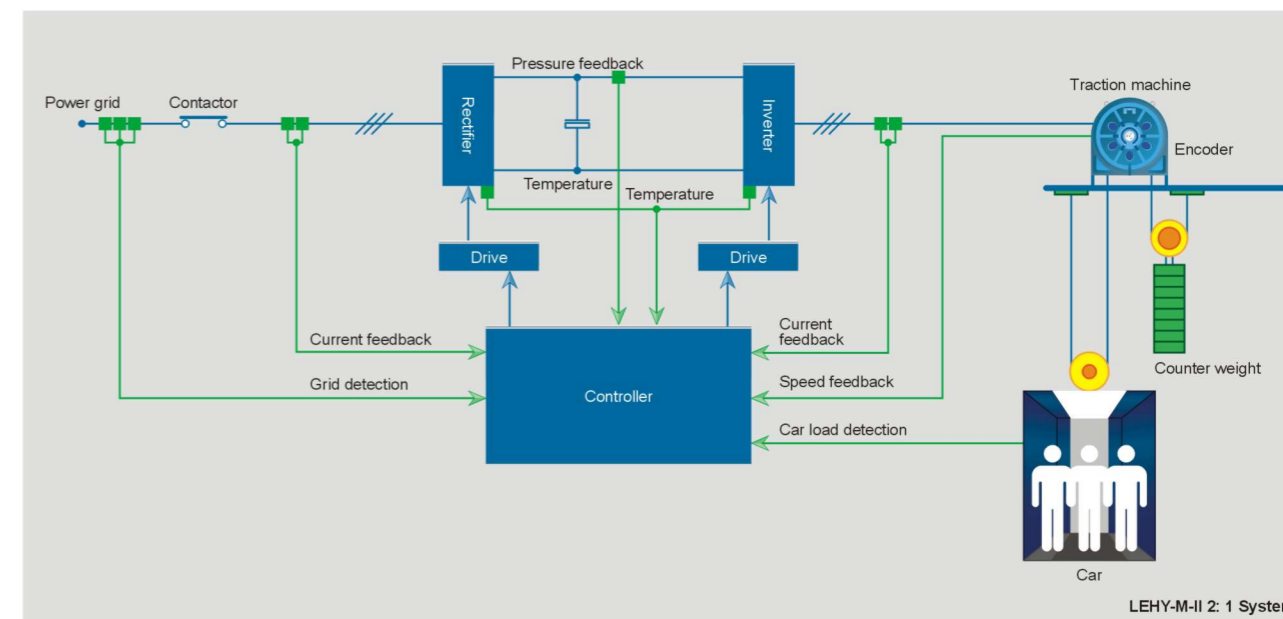

Destination Distribution System (Optional Configuration)

Through efficient destination distribution system, it greatly improves the utilization of the elevator and reduces the average waiting time for passengers. When passengers register which floor they want to go at the landing, the destination distribution system will inform the designated elevator passengers, passengers can go to designated elevator waiting. When the elevator arrives, passengers do not need to press the button of the floor they want to go to, the elevator will automatically register and send the passengers to the destination floor.



Intelligent Group Control System (Optional Configuration)

ITS-21, ITS-2100 group control system adopts a high-performance multi-core CPU processor for computing, to achieve high-speed processing of complex algorithms. High-speed data network effectively improves the throughput and scalability of the system. It applies the expert system, fuzzy logic, neural network technology. According to different traffic conditions, it intelligently provides the dispatching program, greatly reducing passenger waiting time and riding time, and by reducing the ineffective running of the elevator, it can reduce the energy consumption of the elevators in the entire building.

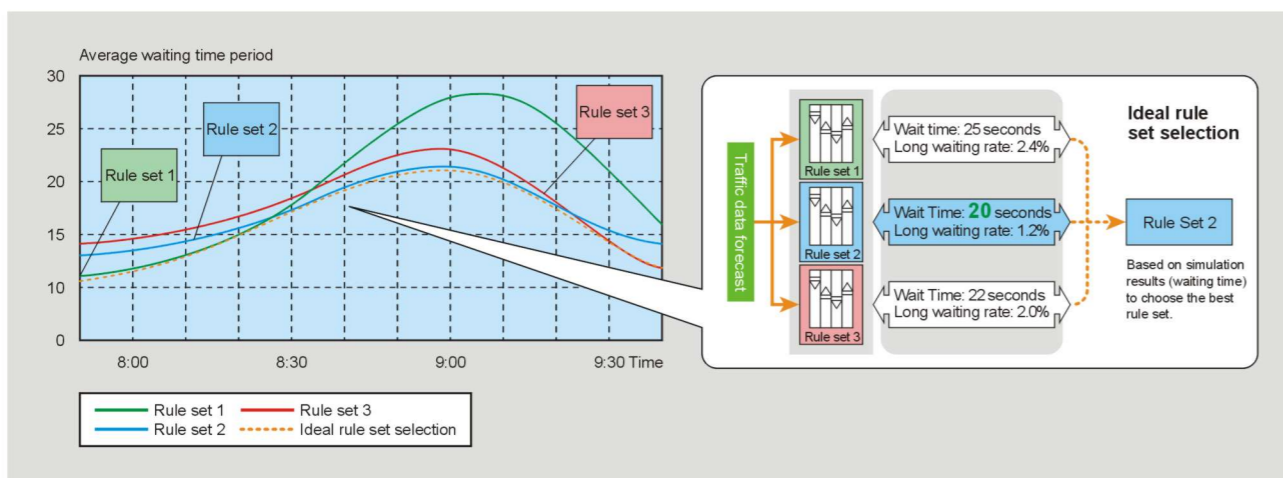

Holistic Car

Shanghai Mitsubishi LEHY-M-II / LEHY-H carefully launched a number of holistic car design options to choose from according to commercial buildings, shopping malls, hotels, and high-end residential and other occasions. It is equipped with a liquid crystal display, and can be configured with elevator air-conditioning. It has high-end large button call, seamless front wall operating panel, and optional multimedia information system (EMIDS). Metallic and mirror (etching, titanium), and a groove (etching, titanium), sand pattern (etching, titanium) and other stainless steel car wall is more suitable for high-end users.



Wall-mounted Landing monitor

Wall-mounted Landing monitor, no tradition bottom box, construction of the wall without holes for easy field installation.



LED Lighting Car Top

The newly developed variety of car top, and the application of environmentally friendly energy-efficient LED lighting enables five times longer in service life than traditional fluorescent tube, saving maintenance costs and at least 50% of the lighting power.

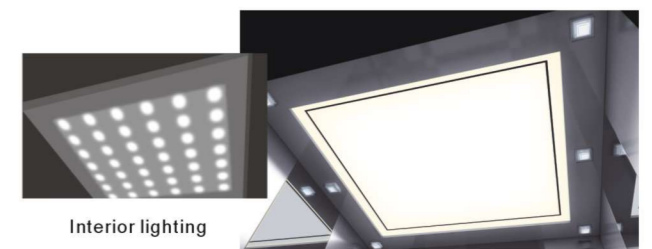

HD 4.3 inch TFT LCD

Resolution up to 800x480, high-definition 4.3 inch TFT LCD, a close look at the real and delicate color, perfectly representing the high-grade quality.



The Brand New Operating Panel and Button Design

The newly designed operating panel has buttons with the maximum diameter of 39.5mm for easier and more accurate operation, more exquisite process, and more comfortable feeling. Provide a variety of resins, zinc alloy buttons, and more accessibility Braille button designed to meet the various needs.





Yong Fung Xuan ZCD-015X

- Car top:** ZCL-GS08.
- Front wall:** Mirror stainless steel.
- Rear of the side wall and both sides of the rear wall:** Marble (Spain beige).
- Front of the side wall and center of the rear wall:** Mirror stainless steel.
- Car door:** Mirror stainless steel.
- Operating panel:** ZCBT-T711. (Optional for other models)
- Upper board at the entrance/exit:** Mirror stainless steel.
- Handrails:** None. (Not configure or choose other models)
- Flooring:** Marble Floor (ZSC-011). (Optional for other models)

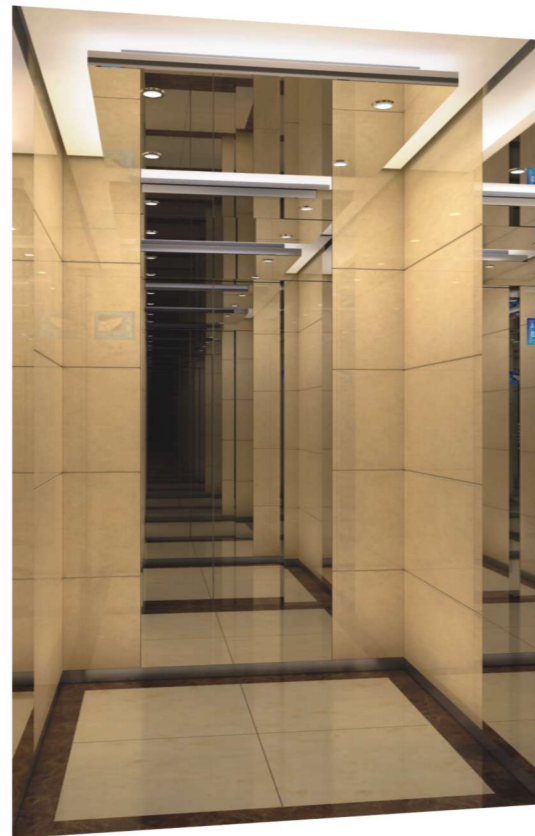

Note: *When configured with integrated operating panel, the front wall and the entrance board material is the same as the operating panel material.
The car comes with a decorative Landing with the required thickness on both sides of 15mm, the rear wall 15mm.

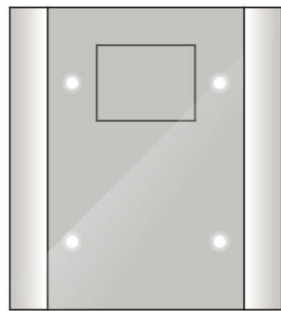

When configured with security window, the ceiling form is floodlight on both sides.



Yin Tai Ge ZCD-019G

- Car top:** ZCL-GS06.
- Front wall:** Hairline stainless steel.
- Both ends of the side wall and the rear wall:** Hairline stainless steel.
- Central sidewall and central rear wall:** Mirror stainless steel.
- Car door:** Mirror stainless steel.
- Operating panel:** ZCBT-H112. (Optional for other models)
- Upper board at the entrance/exit:** Mirror stainless steel.
- Armrest:** Three stainless steel round handrail (ZYH-RH02). (May not match or choose other models)
- Flooring:** Parquet flooring (ZPH-014). (Optional for other models)

Note: *When configured with integrated operating panel, the front wall and the entrance board material is the same as the operating panel material.

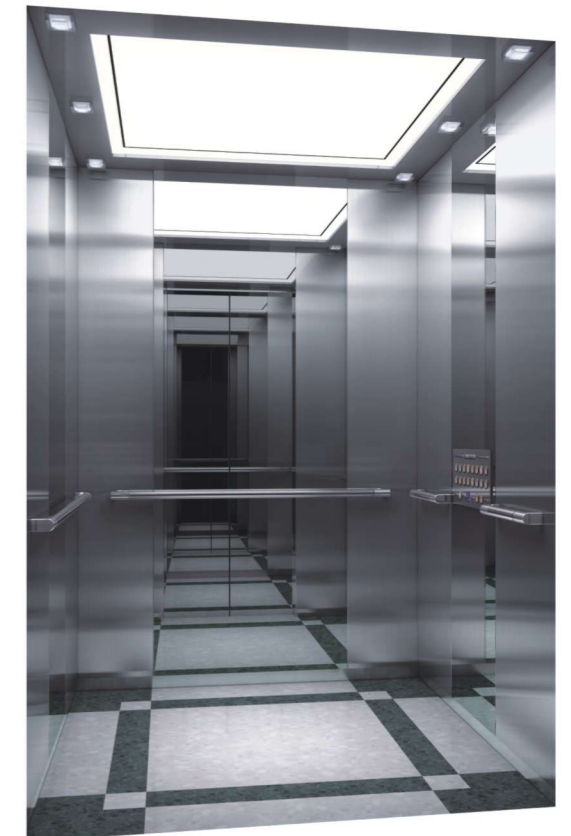

Image is based on computer drawing, may be slightly different from the actual situation. 10



Note: * When configured integrated operating panel, the front wall and the entrance board material is the same as the operating panel material.

Pin Zun Ge ZCD-020G

- Car top:** ZCL-DS12.
- Front wall:** Mirror stainless steel.
- Both sides of the rear wall and the side wall:** Hairline etching titanium stainless steel (ZHF-001).
- Central rear wall:** Mirror stainless steel.
- Car door:** Mirror stainless steel.
- Operating panel:** ZCBK-T311.
(Optional for other models)
- Upper board at the entrance/exit:** Mirror stainless steel.
- Handrails:** Stainless steel ramp handrails on both sides (ZYH-SH01).
(May not deserve or choose other models)
- Flooring:** Marble Floor (ZSC-001).
(Optional for other models)



ZCL-DS12 (Soft Top) LED



Lighting: Central lighting translucent soft film, both sides of the hairline etching titanium stainless steel.

ZCL-GS06 (Square Top) LED



Lighting: Central milky lighting board, surrounded by metallic plates.

ZCL-GS08 (Mirror Top) LED



Lighting: mirror stainless steel ceiling panels, surrounded floodlights and direct flush lighting.

ZCL-CN08 (Empty Top)

Customer selected decoration, with ceiling thickness 200mm.

Material Correspondence Table

Item	Specification	Remarks
Operating panel material	Hairline stainless steel, titanium hairline stainless steel, mirror stainless steel, mirror stainless steel titanium, stainless steel and grain, and grain titanium steel, sand pattern steel, sand pattern titanium stainless steel.	When the main operating panel integrated operating panel.
	Hairline stainless steel, mirror stainless steel.	When the main operating panel is non-integrated operating panel.
Landing monitor panel material	Hairline stainless steel, mirror stainless steel.	When Landing monitor is ZPIT or ZPIK.
Landing call button panel material	Hairline stainless steel, mirror stainless steel.	
Operating panel LCD screen	Shiny purple, refreshing green, elegant brown, blue style.	Operating panel with LCD display.
Landing LCD interface	Shiny purple, refreshing green, elegant brown, blue style.	Landing monitor when ZPIT-CA10, ZPIT-CA20, ZPIK-CA10, ZPIK-CA20, ZPIH-F301, ZPIH-N301 is.
Car wall material	Coated steel sheet, metallic paint steel, steel foil, laminated steel, hairline stainless steel, titanium hairline stainless steel, hairline etched stainless steel, titanium hairline etching stainless steel, mirror stainless steel, titanium stainless steel mirror, mirror etched stainless steel, mirror etching titanium steel, stainless steel and grain, and grain titanium stainless steel, and the groove etched stainless steel, titanium and stainless steel etched lines, sand pattern steel, sand pattern titanium steel, sand pattern etched stainless steel, sand pattern etching titanium stainless steel.	
Front wall materials	Hairline stainless steel, titanium hairline stainless steel, mirror stainless steel, mirror stainless steel titanium, stainless steel and grain, and grain titanium steel, sand pattern steel, Sand pattern titanium stainless steel.	
Car door material	Coated steel sheet, metallic paint steel laminated steel, hairline stainless steel, titanium hairline stainless steel, hairline etched stainless steel, titanium hairline etching stainless steel, mirror stainless steel, titanium stainless steel mirror, mirror etched stainless steel, mirror etching titanium steel, stainless steel and grain, and grain titanium stainless steel, and the groove etched stainless steel, titanium and stainless steel etched lines, sand pattern steel, sand pattern titanium steel, sand pattern etched stainless steel, sand pattern etching titanium stainless steel.	
Landing gate material	Coated steel sheet, metallic paint steel, steel foil, laminated steel, hairline stainless steel, titanium hairline stainless steel, hairline etched stainless steel, titanium hairline etching stainless steel, mirror stainless steel, titanium stainless steel mirror, mirror etched stainless steel, mirror etching titanium steel, stainless steel and grain, and grain titanium stainless steel, and the groove etched stainless steel, titanium and stainless steel etched lines, sand pattern steel, sand pattern titanium steel, sand pattern etched stainless steel, sand pattern etching titanium stainless steel.	
	F-Design-II.	Optional curve open the door.
Door Material	Coated steel sheet, metallic paint steel, hairline stainless steel, titanium hairline stainless steel, mirror stainless steel, mirror stainless steel titanium, stainless steel and grain, and grain titanium steel, sand pattern steel, sand pattern titanium stainless steel.	
Mirror	No, half-length, full-height.	Car optional scheme and 1D1G in decorating.
	Non.	Car overall decorating scheme or 1D2G / 2D2G time.
Railing type	Non, front, side, three sides.	Car optional scheme and 1D1G when decorating.
	No side.	Optional car decorating scheme or 1D2G / 2D2G time.
Floor	PVC real stone floors, parquet flooring.	
	Car under the concave. Marble floor.	When with decorating weight.



Integrated Operating Panel

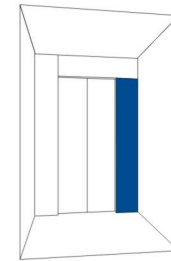

If integrated operating panel is selected, it requires customer's own car decorative wall thickness of the side walls be less than twice decorated 15mm.

When integrated front wall operating panel is selected, it requires the front wall width be not less than 300mm. When configured with the different models of integrated operating panels, the required front wall width and the corresponding maximum number of stops may vary, please confirm with the salesperson.

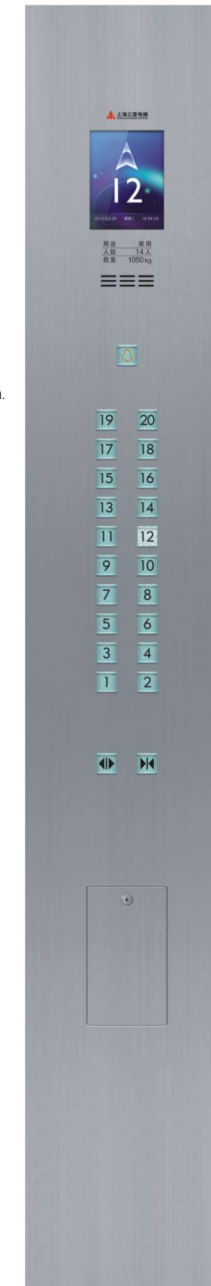

ZCBK-T311 (main)*1
ZCBK-T361 (deputy)*1

Stainless steel panel
HD 8.4 inch TFT LCD
Ice cracks resin
mechanical buttons
Lit with white light



ZCBK-T711 (main)*1
ZCBK-T761 (deputy)*1

Stainless steel panel
10.4 inch Multimedia LCD
Ice cracks resin
mechanical buttons
Lit with white light



ZCBK-T410 (main)*1
ZCBK-T460 (deputy)*1

Stainless steel panel
12.1 inch Multimedia LCD
Ice cracks resin
mechanical buttons
Lit with white light



ZCBK-T810 (main)*1
ZCBK-T860 (deputy)*1

Stainless steel panel
15.0 inch Multimedia LCD
Ice cracks resin
mechanical buttons
Lit with white light



Note: *1 Panel material has the options of hairline stainless steel, mirror stainless steel, sand pattern steel, stainless steel and grain. For the specific materials effect see Shanghai Mitsubishi Elevator Co. decorating palette.

Integrated Operating Panel

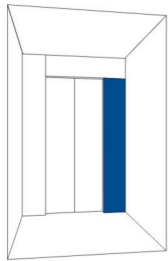

If integrated operating panel is selected, it requires customer's own car decorative wall thickness of the side walls be less than twice decorated 15mm.

When integrated front wall operating panel is selected, it requires the front wall width be not less than 300mm. When configured with the different models of integrated operating panels, the required front wall width and the corresponding maximum number of stops may vary, please confirm with the salesperson.



ZCBT-T313 (main)*1
ZCBT-T363 (deputy)*1

Stainless steel panel
HD 8.4 inch TFT LCD
Zinc alloy Braille mechanical buttons
Lit with orange light

ZCBT-T711 (main)*1
ZCBT-T761 (deputy)*1

Stainless steel panel
10.4 inch Multimedia LCD
Zinc alloy Braille mechanical buttons
Lit with orange light

ZCBT-T411 (main)*1
ZCBT-T461 (deputy)*1

Stainless steel panel
12.1 inch Multimedia LCD
Zinc alloy Braille mechanical buttons
Lit with orange light

ZCBT-T811 (main)*1
ZCBT-T861 (deputy)*1

Stainless steel panel
15.0 inch Multimedia LCD
Zinc alloy Braille mechanical buttons
Lit with orange light



Embedded Operating Panel

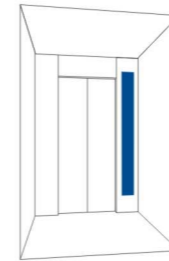

When the front wall width is less than 250mm, embedded operating panel is mounted on the side wall of the car.



ZCBT-H112 (Main)
ZCBT-H162 (Sub)

Stainless steel panel
Orange LED dot matrix display
Zinc alloy Braille mechanical buttons
Lit with orange light



Wheelchair Operating Panel



ZCBT-F050

Stainless steel panel
Zinc alloy Braille mechanical buttons
Lit with orange light



ZCBV-C120

Stainless steel panel
Convex resin Braille text on the button
Orange LED dot matrix display
Lit with orange light
Operating panel in line with GB / T24477 standards



Note: *1 panel material has the options of hairline stainless steel, mirror stainless steel, sand pattern steel, stainless steel and grain. For the specific materials effect see Shanghai Mitsubishi Elevator Co. decorating palette.

Embedded Landing monitor



ZPIK-CA10
Stainless steel panel
HD 4.3 inch TFT LCD
Ice cracks resin
mechanical buttons

ZPIK-CA20
Stainless steel panel
HD 4.3 inch TFT LCD
Ice cracks resin
mechanical buttons

ZPIT-CA10
Stainless steel panel
HD 4.3 inch TFT LCD
Zinc alloy Braille
mechanical buttons

ZPIT-CA20
Stainless steel panel
HD 4.3 inch TFT LCD
Zinc alloy Braille
mechanical buttons

Wall-mounted Landing monitor



ZPIT-G111*1
Stainless steel panel
Orange LED
dot matrix display
Zinc alloy Braille
mechanical buttons

ZPIT-G121*2
Stainless steel panel
Orange LED
dot matrix display
Zinc alloy Braille
mechanical buttons

Landing Call Button

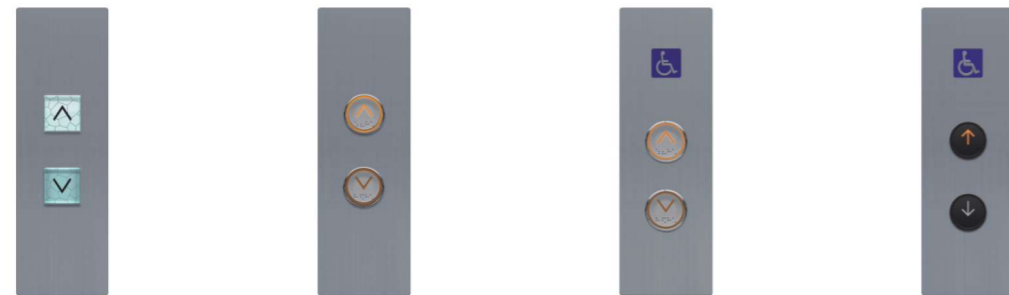

ZHBK-C010 (single)
ZHBK-C020 (combined)
Stainless steel panel
Ice cracks resin
mechanical buttons
Lit with white light

ZHBT-C012 (single)
ZHBT-C022 (combined)
Stainless steel panel
Zinc alloy Braille
mechanical buttons
Lit with orange light

ZHBT-C030 (single)*3
ZHBT-C040 (combined)*3
Stainless steel panel
Round Zinc Alloy
Braille mechanical buttons
Lit with orange light

ZHBV-C030 (single)
ZHBV-C040 (combined)
Stainless steel panel
Resin Braille
mechanical buttons
Lit with orange light

Note: *1 Operation modes are optional except for ITS-2100.
*2 Operation modes are optional except for 1C-2BC and ITS-2100.
*3 Cannot be configured separately, need to be configured with ZPIT or ZPIK series landing monitors.

Multimedia Information Display System (EMIDS)

With a more powerful processing system and more delicate LCD screen, it is updated on the basis of hardware and develops a variety of new design interface. Realize the elevator floor signal indicative of simultaneously excellent displaying of the multimedia information, in a small elevator space for the owners to do advertising, and also for the passengers to have a more pleasant riding experience.

From the demand of the passengers of the elevator, Shanghai Mitsubishi has developed several new EMIDS interface: full screen, the user can display the contents of the largest area information; classic, which can meet most customer needs; forecast model: forecast the next floor information, providing tips to passengers to get ready for the next floor. Preset five kinds of interface designs, which can be changed at will.



Full screen



classic A classic B Forecast standing A Forecast standing B

LCD

A new generation of LCD uses advanced hardware driver circuit with the more delicate LCD screen and features a new interface design, giving new life to ordinary LCD, more lively, more vivid, and more enjoyable. Typical four-style interface designed to meet the needs of different styles and decorating the car.

Horizontal elevator indication

(for operating panel inside the car, landing TFT LCD 5.7 inch)



Shine purple-Standard Refreshing green-Residential



Your elegant brown-Hotel Stylish blue-Business

Vertical elevator operation indication

(for operating panel inside the car 8.4 inch)



Shine purple-Standard Refreshing green-Residential



Your elegant brown-Hotel Stylish blue-Business

Vertical elevator operation indication

(for landing TFT LCD 4.3 inch)



Shine purple-Standard Refreshing green-Residential Your elegant brown-Hotel Your elegant brown-Hotel

Landing Door and Door Cover

E-102 Narrow Door



Landing call button: ZPIT-G111
Landing gate material: coated steel
Door Material: coated steel

E-302 angled (10o) door sets



Landing direction lights: ZPIH-F301 refreshing green
Landing call button: ZHBK-C010
Landing gate material: Hairline stainless steel
Door Material: Hairline stainless steel

E-312 screen plate bevel (10o) door set



Landing direction lights: ZHLV-H010
Landing call button: ZHBT-C012
Landing gate material: stainless steel hairline etching (Color: ZHY-006)
Door Material: Hairline stainless steel

E-322 swash plate curtain bevel (10o) door set

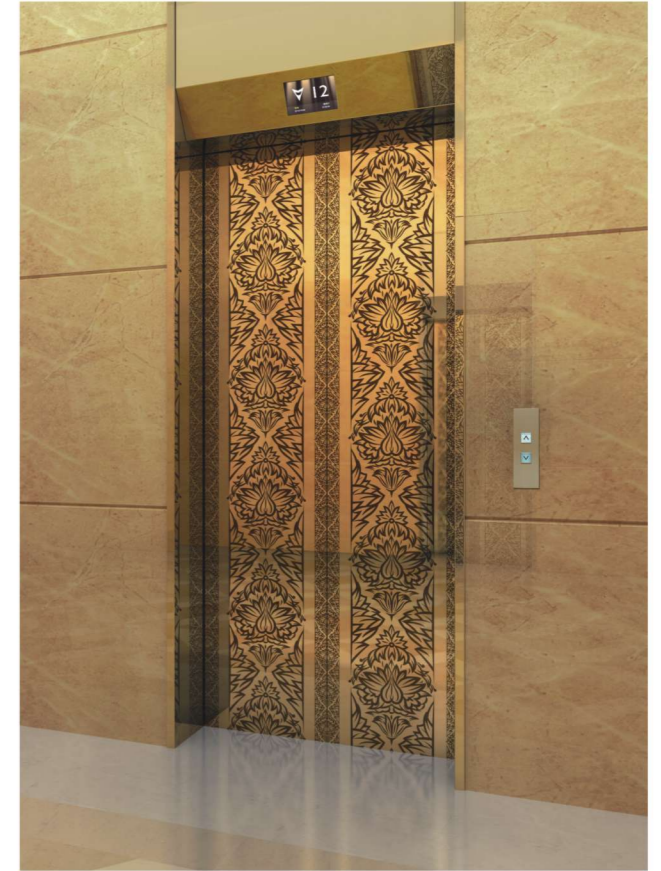

Landing direction lights: ZPIH-N301 Elegant brown
Landing call button: ZHBK-C010
Landing gate material: Mirror sandblasted titanium-plated stainless steel color (ZPF-001)
Door Material: Mirror titanium stainless steel (ZDT-002)

Landing Direction Light



ZHLV-B011*1 Mirror stainless steel panel. Fog light white acrylic sheet.	ZHLV-E021*1 Mirror stainless steel panel. Fog light white acrylic sheet.	ZHLV-H010*1 No panel. Fog light white acrylic sheet.	ZHLV-E011*1 Mirror stainless steel panel. Transparent acrylic sheet.	ZHLV-R011*1 Mirror stainless steel panel. Fog light white acrylic sheet.	ZHLV-R021*1 Mirror stainless steel panel. Transparent acrylic sheet. (Surface partial sandblasting)	ZHLV-E031*1 Mirror stainless steel panel. Transparent acrylic sheet.
--	--	--	--	--	--	--

Note: *1 or more selectable direction light emitting color is warm white, is white and red and green (red on behavior, behavior under green)

Landing Monitor



HID-A10
Large-scale landing embedded displays without panel
LED orange dot matrix
Door type is applicable when the E-312

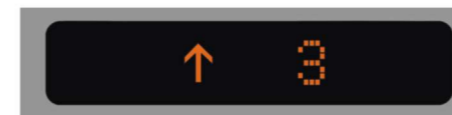

HID-A20
Embedded large Landing monitor
LED orange dot matrix
Door types of non-E-312, E-322 as applicable



ZPIH-N301
Large-scale landing embedded displays without panel
HD 8.4 inch TFT LCD
Door type is applicable when the E-322



ZPIH-F301
Wall-mounted large-scale Landing monitor
HD 8.4 inch TFT LCD
Transparent acrylic frame, matt chrome panel

Mirror



Half-length mirror

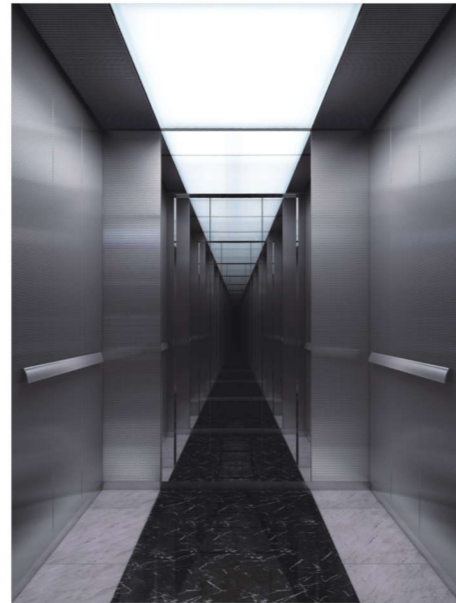

Full-length mirror

Type of armrest

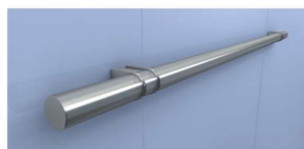

ZYH-RH01
Stainless steel round handrail

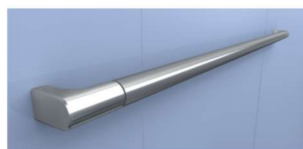

ZYH-RH02
Stainless steel round handrail

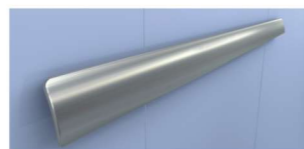

ZYH-SH01
Leaned stainless steel handrail



ZYH-FH10
Stainless steel flat handrail

Flooring (PVC real stone floor, color swatches selected in accordance with Shanghai Mitsubishi decorating is also optional)

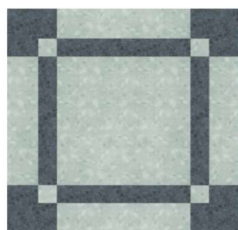

ZPH-014
Parquet

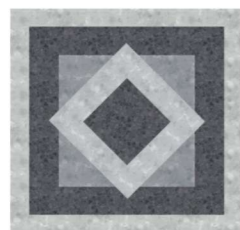

ZPH-016
Parquet



ZPH-018
Parquet

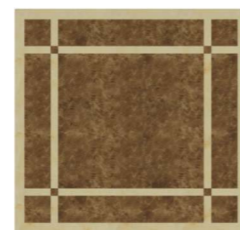

ZPH-019
Parquet

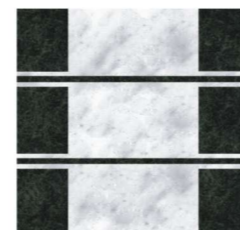

ZPH-020
Parquet

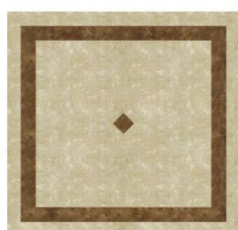

ZPH-021
Parquet

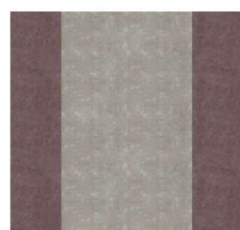

ZPH-022
Parquet

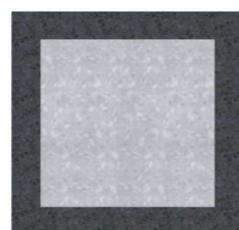

ZPH-023
Parquet



ZSC-001
Marble floor



ZSC-011
Marble floor

Note: See page 12 for Material Correspondence Table.

Function Name	Function Description	Function code	1C-2BC	2-4C ITS-21	3-8C ITS-2100
Control and Security					
Automatic re-leveling	After the arrival and stop of the car, when the deviation between the vertical plane of the upper plane and ground plane landing exceeds a predetermined value, the elevator automatic gets to the aiming storey.	ARL	③	③	③
Elevator blocked Stall protection	When the hoisting rope slip or motor stall reaches a predetermined time, the elevator stops running.	AST	③	③	③
Brake redundancy protection	When a group of brake failure, the rest of the elevator brake can also achieve effective braking.	BTUP	③	③	③
Energy Feedback	Feedback the energy generated during the running, so as to save energy.	EFDBK	③	③	③
Electrical safety circuit protection	Electrical safety devices connected together in series, once the action, then stop the elevator.	ESC	③	③	③
Storey self determination	Automatic measurement and data recording storey.	FMR	③	③	③
Maintenance Operation	Inspection running mode used by personnel for maintenance.	HAND	③	③	③
High Power Factor Rectifier	High power factor rectifier.	HAPC	③	③	③
Weighing start	The elevator adjusts the starting torque according to the load inside the car, so as to smoothly start the elevator.	LWS	③	③	③
Over-current protection	When detecting fairing or inverter device current is too large, the elevator stops.	OCP	③	③	③
Over-speed protection	When detecting the speed exceeds the allowable value, the elevator stops.	OSP	③	③	③
Motor overheating protection	When detecting motor overheating, the elevator stops.	OTP	③	③	③
Overvoltage protection	When detecting voltage rectifier or inverter device is too high, the elevator stops.	OVP	③	③	③
Power failure protection	When it is lack of power-off phase, under-voltage fault, the elevator stops.	PFP	③	③	③
Re-leveling power	Due to power outages caused by a car parked in the door zone range, when the power is restored, the car will get to a further aiming storey.	PORL	③	③	③
Retrograde protection	Elevator detected retrograde, then stopped the elevator.	RSP	③	③	③
Fixed Landing selection	Elevator during operation of the selected Landing is to be amended.	SC	③	③	③
Safety stops	For some reason when the elevator stopped at the outer door zone, the controller safety testing, if they meet the start-up requirements, the elevator stops at the nearest landing.	SFL	③	③	③
Stop Landing open	Elevator automatically opens the door after the elevator stops at the landing.	SO	③	③	③
Inverter device temperature detection	When inverter is detected for overheating, stop the elevator.	THMF	③	③	③
Terminal compulsory deceleration	If when the car runs to the terminal landing while the speed is reduced to a predetermined value, the system forcibly slow down to a normal level of the car floor.	TSD	③	③	③
Speed too low protection	Detected running speed is lower than the allowable value, the elevator stops.	USP	③	③	③
Electronic terminal floor forced decelerating device		SETS*1	②	②	②
Operation and Service					
Full load auto adoption	Car load exceeds 80% of the rated load (can be adjusted), the elevator does not respond to the call along the landing.	ABP	②	③	③
Chauffeur service	Normal operation of the elevator to be completed by the driver.	AS	②	②	②
Exception handling computer operating panel	When an exception occurs at the computer operating panel, after the nearby dock landing, the elevator will not start.	CCBK	③	③	③
Reverse instruction to eliminate the command inside the car	Elevator operates automatically, when the elevator along the complete response within the last car or landing call instruction, the system will automatically check for and eliminate the rest of the car in order.	CCC	③	③	③
Car ventilation system shut down automatically	After the no direction standby of the elevator a certain time, the ventilation system in the car is automatically turned off to save energy.	CFO-A	②	②	②
Car interior illumination turned off automatically	After the no direction standby of the elevator a certain time, the lighting in the car is automatically turned off to save energy.	CLO-A	②	②	②
Continuous Service	To ensure the normal operation of the entire group elevator, the elevator does not respond when a landing has registered a landing call, it will be excluded from the landing call services, for other elevators to serve.	COS	—	③	③
Elevator dedicated air-conditioning	Non-standard signing sheet shall to be marked with single cooling or both cooling and heating type.	EAC*1*2	②	③	③
Fault diagnosis	Elevator abnormality and fault diagnosis during operation.	EFD	③	③	③
Emergency exit switch	For emergency exit state detection switch.	EXIT SW	②	②	②
The car in automatic elimination of erroneous instruction	If the number does not match with the number of passengers in the car instruction has been registered, in order to avoid all unnecessary stopping instructions.	FCC-A*3	②	②	②
Eliminate erroneous instruction manual (button inside the car type) in the car	Mistakenly press the button in the car instruction, double-tap the button to cancel the instruction.	FCC-P*4	②	②	②
Landing mistakenly call artificial eliminate (landing button type)	Mistakenly press the landing call button, double click the button, and cancel the call.	FHC-P	②	②	—
Landing call automatic registration	When an elevator does not pick up all the passengers, the landing buttons holds the registration status, and the system will automatically assign another elevator to service.	FSAT	③	③	③
Group control backup operation	In group control processor failure and group control and all communication failure caused group control failure, maintain the function of each elevator service.	GCBK	—	③	③
Landing microcomputer exception handling	When abnormality occurs, the elevator docks at the nearby landing, and cannot start again.	HCBK	③	③	③
Medical Operation (button type)	Press the button and the door open to extend the button, then elevator only responds to commands in the car.	HE-B*5	②	②	②
Landing run control switch	By operating installed on the designated landing "Run / Stop" key switch, turn on or off the elevator.	HOS	③	③	③
Landing run control switch (Timer type)	Through the application of a timer, turn on or off the elevator.	HOS-T*1	②	②	②
Standalone	Use the operating panel "independence" switch, you can run without interruption, and not only in response to the car in response to the landing call instruction.	IND	③	③	③
Forced to close	If the elevator door holding time exceeds the predetermined value, the elevator temporarily ignores the role of non-contact door sensors, forces closing.	KNDG	③	③	③
Non-service Landing settings (switching)	Operation of the switch, cancel the designated landing services.	NS*1*6	②	②	②
Non-service Landing settings (inside the car push-button type)	By pushing the operating panel buttons and setting switch, cancel the specified landing services.	NS-CB	②	②	②
Elevator does not start alarm	In landing call, the car instruction has been registered, but the elevator cannot be started within a predetermined time, then remove the assigned hall call, leave the car in instruction, unusual lights, and abnormal alarm sounds.	NST*7	③	③	③
Non-service landing settings (Timer type)	Cancel designated landing of service within the specified time.	NS-T*1	②	②	②
Docked at the second Landing	After the elevator reaches the destination landing, if the car door is not fully open, continue to run after the next Landing is closed until the door is fully opened, the resume normal operation.	NXL	③	③	③
Overload alarm	When the car is overloaded elevator door is kept open and buzzer sounds are kept in the car.	OLH	③	③	③
Remote control Stop elevator	By remote control switch, start or stop the elevator.	RCS*8	②	②	②
Return running	Operation return switch will immediately recall the elevator to the designated floor stand.	RET*8	②	②	②
Cryptographic service (push-button type inside the car)	By setting a password lock on some floor operating panel, press the password on the operating panel to register the designated floor.	SCS-B*9	②	②	②
Cryptographic service (IC card type)	Through the IC card to the registration of certain designated floor button.	SCS-IC*1	②	②	②

③ 蓝色为标准功能；② 粉色为选配功能。

Function Name	Function Description	Function code	1C-2BC	2-4C ITS-21	3-8C ITS-2100
■ Emergency Operation					
Car emergency lighting	In the normal lighting power outage, immediately provide car lighting.	ECL	④	④	④
Earthquake emergency return (S-wave)	In the S-wave seismic detectors action, immediately stops the elevator at the nearest landing, holding the door shut.	EER-S	④	④	④
Blackout emergency stop	In normal power outage, elevator powered by the device, the car run to the nearest landing, leveling door, allowing passengers to leave safely.	ELD*10	④	④	④
Bell	When pressing the emergency alarm, the alarm and the call device sound.	EMB	④	④	④
Fire returns	When the fire protection return switch works, cancel all calls of all landings, as well as the instructions in the car, the elevator returns immediately to the predetermined landing and the door is shut.	FER*11	④	④	④
Backup power supply to run (automatic)	In the loss of normal power, make use of the building back-up power supply, and the elevator will automatically execute pre-assigned sequential motion to the designated landing. Once all elevator landings have reached the predetermined levels, the designated elevator returns to the normal operation.	OEPS-SA*12	④	④	④
Elevator monitoring system	The system uses a computer to monitor the status and location of the elevator, and provides operational instructions when necessary.	SMOS-II	④	④	④
■ Door Operating					
Close protection	When the car door is not completely closed, the door opens in a reversed direction.	CLTS	④	④	④
Commutation re-opening	Elevator door open state, in the car on the forward direction there is no command or landing call, landing all in the opposite direction has been registered, and the elevator door is closed immediately and re-opened.	DDOP	④	④	④
Extend the button to open the door	Press this button to extend the elevator door holding time.	DKO-TB	④	④	—
Door load detection	If the door cannot be fully opened or closed due to overload, the elevator door will in the reverse direction operation.	DLD	④	④	④
Door blocked control	If the elevator door is blocked, it will be immediately closed.	DONG	④	④	④
Open holding time automatically adjusted	The door holding time is automatically adjusted according to the landing call instructions inside the car.	DOT	④	④	④
Closing torque control	If the elevator encounters extra resistance in closing, the door system automatically increases torque.	DTC	④	④	④
Instant closed	Elevator stops after opening, the close button is pressed, and the door is closed immediately.	EDC	④	④	④
Safety light curtains touch panel	Touch panel with safety light curtain. The use of dual protection of light curtains and safety edge, during the closing, when passengers or object are detected, the door will be re-opened.	MBS*13	④	④	④
Bell forced close	If the elevator door holding time exceeds the predetermined value, the elevator sounds an alarm to remind passengers and tries to close the door.	NDG	④	④	④
Repeat closed	If the door is blocked, the elevator door closing operation will be repeated until the debris is cleared.	RDC	④	④	④
Door re-opening at this landing	In the closing process, press the landing call button of the same direction, the elevator door re-opens.	ROHB	④	④	④
Safety edge	In the closing process, the door safety edge detects a passenger or objects, the door will be re-opened.	SDE*13	④	④	④
Door optoelectronic protective device	In the closing process, when the infrared door safety device detects the passenger or object, the door will be reopened.	SR*14	④	④	④
■ Information and Display					
Voice announcement apparatus for landing (Chinese)	Passenger-related information from the voice to stop the elevator notification (Chinese).	AAN-S01*15	④	④	④
Voice announcement apparatus for landing (Chinese and English in turn)	Passenger-related information from the voice to stop the elevator notification (Chinese and English in turn).	AAN-S02*15	④	④	④
Voice announcement apparatus for landing (English)	Voice announcement by the device (in English) to inform passengers of the elevator-related information.	AAN-S03*15	④	④	④
Car landing electronic chime unit	Electronic chime prompts passenger car has reached the destination landing. (Electronic homophonic installed in the car at the top and bottom)	AECC*16	④	④	④
Landing electronic chime unit	Electronic chime prompts passenger car has reached the destination landing. (Electronic chime installation landing)	AECH*16	④	④	④
Instant forecast	Once registered passenger landing call, and immediately selected the most appropriate response to this call the elevator, and to inform passengers through visual / audible signal.	AIL	—	—	④
Landing instructions to run automatically	The display shows the elevator landing in automatic operation, indicating the character as "automatic."	AUTL*17	④	④	④
Signal interface device	The output of the elevator of the basic operation status signal	BA*118	④	④	④
Landing direct running indication	Landing monitor run in a direct elevator running status and the indicator character is "fully loaded."	BPL*17	④	④	④
Inside the car running direction indication	In the running direction of the elevator car is represented by an arrow.	DAC	④	④	④
Landing run direction indication	In landing the direction indicated by arrows elevator.	DAH	④	④	—
Close button response indication	Close button lamp lit at the same time pressing the close button.	DCR	④	④	④
Door button response indication	Door button lamp lit at the same time pressing the button to open the door.	DOL	④	④	④
Button to open the door to extend the response indication	Audio and video and other information can be provided to passengers (mounted operating panel).	DKOL*19	④	④	④
Multimedia display inside the car	Audio and video and other information can be provided to passengers (installed in the car).	EMIDS-C*1	④	④	④
Operating panel multimedia display	When the door opening extension button is pressed, the indicator is lit continuously for some time.	EMIDS-COP*20	④	④	④
Landing multimedia display	Audio and video and other information can be provided to passengers (installed in the landing).	EMIDS-H*1	④	④	④
Dedicated service instruction	Elevator in dedicated service status display.	EXCL*17	④	④	④
Fire return completion	Fire return after the end of the run, output an end signal.	FER-CP*21	④	④	④
FER instructions inside the car run	When the elevator enters into the fire emergency return service in fire, the state is indicated in the car.	FERC*22	④	④	④
Multiparty call device	Emergency, in the car or car top or bottom pit can communicate through the device and the computer room or the control room of people.	ITP*23	④	④	④
ITV cable	Cable inside the car video equipment for use by the user.	ITV*24	④	④	④
Camera monitoring capabilities	SMOS-II system configuration matching the elevator camera surveillance capabilities.	ITV-S*25	④	④	④
End run backup power supply	After the back-up power supply run, output an end signal.	OEPS-CP*26	④	④	④
Overload indication inside the car	When the elevator overload, overload indicator light.	OLHL*27	④	④	④
Elevator disabling instruction	Indicates elevator is inactive at the landing place.	RESL*17	④	④	④
Secondary to the car forecast	During peak operation, when an elevator cannot pick up all passengers, the next service elevator landing forecast light flashes.	TCP	—	—	④
Landing button light flashes indication	Elevator landing stops, beginning to open the door, landing in the same direction of the call button lights flashing, to remind passengers have a elevator, when the elevator door closing arrival, the button light turns off.	FHBL	④	④	④
Landing monitor power-saving function	No passengers landing call registration of the dot matrix display in low light mode, and press only when the normal brightness level is displayed in this call button, to save power and prolong monitor life.	HIES*28	④	④	④

④ 蓝色为标准功能； ④ 粉色为选配功能。

Function Name	Function Description	Function code	1C-2BC	2-4C ITS-21	3-8C ITS-2100
■ Group Control					
Group control grouping	The landing buttons divided into several groups, packet group to provide independent control, each have their own landing call button.	BSO	—	④	④
Elevator allocation adjustment	When the group control, group control system in accordance with the actual situation in real-time adjustment of the elevator is dispatched.	CAT	—	—	④
Rush hour service	When in meetings, etc. caused due to the temporary congestion, the system will try to arrange the elevator to go to the crowded hall to meet demand.	CFS*29	—	④	④
Closest elevator priority service	When the elevator landing call answers, elevator standing on the same floor is dispatched to the landing closest to the landing as the priority.	CNPS	—	—	④
The destination distribution system	When the lower landing operating panel destination landing button is pressed, the system forecasts the service elevator number. Allocate according to the destination floor elevator system to improve traffic efficiency.	DOAS-S*1	—	—	④
Crowded landing service	Work within a predetermined time, the top priority to continue dispatching work to meet peak demand during the run.	DPS	—	④	④
Energy saving operation (number of unit control)	In consideration of passenger traffic and to meet the needs of the situation, when the elevator's service level has exceeded the specified target, the system will reduce the number of elevators in service in order to save energy.	ESO-N	—	④	④
Rush hour service	Elevator with forced specific landing must be docked at the landing.	FFS*30	④	④	④
Group control self-diagnosis	When the group control system fails, the system records the fault log, available to the group control monitoring device.	GCS	—	—	④
Lunch time service	Deployment of the passenger elevator to accommodate the lunchtime crowded situation, to service the guests out of the restaurant guests as priority.	LTS*31	—	④	④
Main landing standby	When the elevator without landing in the car and call instructions, return to the main landing standby.	MFP	④	—	—
Prevent running	This feature prevents installation on the same elevator shaft while running so the car noise rises in emergency line area.	PRS	—	④	④
Service at peak time	Alleviate temporary transportation busy, as the priority the elevator is automatically assigned to the most crowded landing (top Landing or master landing).	PTC	—	④	④
Specifies the elevator priority services	In the group control system, the designated landing call, priority in the allocation assigned elevator to services (such as tourism staircase or elevator with basement service).	SCPS*32	—	—	④
Specify Landing priority services	For some call the designated landing priority allocation to service elevator.	SFPS*33	—	—	④
Dynamic dispersion standby	The system takes into account the traffic situation throughout the building, predicted landing most in need of services, and then assign an elevator accordingly based on these predictions.	SOHS	—	④	④
Main floor changeover	Operate the switch to change the main landing.	TFS*1	④	④	④
Light load elevator priority service	In less traffic, priority allocation load or light load (load less than 10%) of the car.	UCPS	—	—	④
Specific Landing forced stop	Working within a predetermined time, and the main landing up when transport particularly busy, continue to give priority to the main floor dispatching landing to meet peak demand during work.	UPS	—	④	④
VIP Service	A special elevator can be withdrawn from the group control, and designated for VIP service.	VIP-S*34	—	④	④

④ 蓝色为标准功能； ④ 粉色为选配功能。

Note: *1 Non-standard.

- *2 On non-standard routing slip, mark the single cooling or both heating and cooling type.
- *3 Landing number is larger than or equal to 6 Landings and not optional when configuring the SCS-IC function.
- *4 When SCS-IC function is not configured, it is optional
- *5 Optional functions when DKO-TB is configured.
- *6 NS switch installed by default in the main staircase manipulation box, on a non-standard routing slip must state the name of the landing NS non-service Landing.
- *7 Abnormal signal output from SMOS-II.
- *8 User or SMOS should provide a dry contact signal to the control cabinet.
- *9 Choose one from SCS-B and SCS-IC.
- *10 Optional when the adjacent landing distance is 10m or less.
- *11 Elevators can be considered within 60 seconds from the top end of the landing to return to FER return Landing.
- *12 Users are required to provide regular and backup power normally open dry contact signal, and the need to provide automatic control of dry contact signals that invite users to the engine room control cabinet.
- *13 Choose one from SDE and MBS.
- *14 Optional for SDE
- *15 Choose one of the three AAN-S01, AAN-S02 and AAN-S03 at most.
- *16 Choose one of AECC and AECH at most.
- *17 Landing instructions to select the number of no more than two.

- *18 Output signal is upstream, downstream, integrated fault, landing coded signal. The output signal terminal in the engine room control cabinet. The output mode is dry contact output and RS485 serial communication.
- *19 When configured with DKO-TB.
- *20 When Car operating panel is one of the following model standards: ZCBT-T711, ZCBT-T411, ZCBT-T811, ZCBK-T711, ZCBK-T410, ZCBK-T810, ZCBK-T761, ZCBT-T461, ZCBT-T861, ZCBK-T761, ZCBK-T460, ZCBK-T860.
- *21 Standard for FER.
- *22 Optional for FER.
- *23 engine rooms to the control room of the cable and install themselves by the user.
- *24 Choose one from ITV and ITV-S.
- *25 Choose one from ITV and ITV-S and equipped SMOS-II optional.
- *26 Optional when equipped with OEPS-SA.
- *27 Selection number in the car indicates no more than three.
- *28 Optional when configured with HID-A10 or HID-A20 landing monitor.
- *29 Specify the name of the landing crowded Landing on the non-standard will be signing.
- *30 Mandatory stop at landings must specify the landing name.
- *31 Specify the name of the landing for lunch.
- *32 Designate priority service elevator number.
- *33 Specify the name of the landing priority services.
- *34 Specify the VIP elevator number and VIP standby standing.

Basic Specification Table (LEHY-M-II)

Item	Specification Content				Remark
Speed (m / s)	2.5	3.0	3.5	4	When the heavy side to set a maximum speed of 3.5m / s.
Load (kg)	1050	1050	1050	1050	
	1200	1200	1200	1200	
	1350	1350	1350	1350	
	1600	1600	1600	1600	
	1800	1800	1800	1800	
	2025	2025	2025	2025	
Number of landing (landing)	2-48	2-48	2-48	2-48	
Elevate the height TR (m)	14.6-120	18.8-150	24.2-150	29.8-150	
Operation	1C-2BC, 2C-ITS-21, 3C-ITS-21, 4C-ITS-21, 3C-ITS-2100, 4C-ITS-2100, 5C-ITS-2100, 6C-ITS-2100, 7C-ITS-2100, 8C-ITS-2100				
Control method	VFH-H				
Energy Feedback	Have				
Traction machine origin	SMEC				
Specifications Code	P14W				1050kg load time.
	P16W				1200kg load time and after resetting
	P-16				1200kg of weight load and in the side
	P18W				1350kg load time and after resetting
	P-18				Load 1350kg for the side counter weight.
	P21W				1600kg load time and after resetting
	P21W, P21D				1600kg load for the side counter weight
	P24W				1800kg load time and after resetting
	P27W				2025kg load and reset time after.
Open the door	Separate type				
	Double folding				Optional when car code is P21D.
Door System	LV1K-L2N-CO				
	LV2K-L3N-2S				Optional when car code is P21D.
Open type	1D1G				
	1D2G, 2D2G				Car code P21D and the counterweight side-mounted, non-standard options.
Car decoration scheme	Optional program				
	Overall program				Optional for 1D1G and separate doors.
Overall car code	ZCD-015X, ZCD-019G, ZCD-020G				Optional when decorating the car is the overall program.
Power supply	380V50Hz three-phase five-wire system				
Lighting power	220V50Hz single-phase				
Delivery Code	SMT				
Counterweight position	Rear position				
	Side position				≤1600kg load and rated speed 2.5, 3, 3.5m / s when.
Counterweight safety gear	Not configured, configured				
Door temporary closure plate	Buyer self run, seller provides				
Corbels	Buyer self run, seller provides				
Minimum storey (mm)	≥2600				Steel bracket and HH = 2100.
	≥2700				Steel bracket and HH = 2200.
	≥2800				Steel bracket and HH = 2300.
	≥2900				Steel bracket and HH = 2400.
	≥2800				Concrete bracket and HH = 2100.
	≥2900				Concrete bracket and HH = 2200.
	≥3000				Concrete bracket and HH = 2300.
Landing monitor range	B1, B2, B3, B4, B5, B, G, M, -1, -2, -3, -4, -5, 1, 2, 3, 4, 5, 6, 7, 8, 9, 10, 11, 12, 13, 14, 15, 16, 17, 18, 19, 20, 21, 22, 23, 24, 25, 26				
	27, 28, 29, 30, 31, 32, 33, 34, 35, 36, 37, 38, 39, 40, 41, 42, 43, 44, 45, 46, 47, 48				
	3A, 5A				
	12A, 12B, 13A, 15A, 17A, 23A				Optional except the wheelchair operating panel ZCBV-C120

Please contact the company's business department if it is beyond the scope of the aforementioned specification.

Basic Specification Table (LEHY-H)

Item	Specification Content		Remark
Rated speed (m / s)	5.0	6.0	
Rated load (kg)	1200	1200	
	1350	1350	
	1600	1600	
	1800	1800	
Maximum number (landing)	48	48	
Maximum elevator height TR (m)	250	250	
Operation	1C-2BC, 2C-ITS-21, 3C-ITS-21, 4C-ITS-21, 3C-ITS-2100, 4C-ITS-2100, 5C-ITS-2100, 6C-ITS-2100, 7C-ITS-2100, 8C-ITS-2100		
Control method	VFH-H		
Energy feedback	Have		
Traction machine place of origin	SMEC		
Open the door	Separate type		
Door system	LV1K-L2N-CO		
Open type	1D1G		
Car decoration scheme	Optional program, the overall program (non-standard)		
Overall car code	ZCD-001X, ZCD-001G, ZCD-002G, ZCD-002X (when decorating the car overall scheme is optional)		
Power supply	380V50Hz three-phase five-wire system		
Lighting power	220V50Hz single-phase		
Minimum storey (mm)	≥2600		Steel bracket and HH = 2100.
	≥2700		Steel bracket and HH = 2200.
	≥2800		Steel bracket and HH = 2300.
	≥2900		Steel bracket and HH = 2400.
	≥2800		Concrete bracket and HH = 2100.
	≥2900		Concrete bracket and HH = 2200.
	≥3000		Concrete bracket and HH = 2300.
Delivery code	SMT		
	Postposition		
Counterweight position	Nott configured, configured		
Bracket	Buyer self run, seller provides		
Landing monitor range	B1, B2, B3, B, G, M, -1, -2, -3, 0, 1, 2, 3, 4, 5, 6, 7, 8, 9, 10, 11, 12, 13, 14, 15, 16, 17, 18, 19, 20, 21, 22, 23, 24, 25, 26		
	27, 28, 29, 30, 31, 32, 33, 34, 35, 36, 37, 38, 39, 40, 41, 42, 43, 44, 45, 46, 47, 48		

Please contact the company's business department if it is beyond the scope of the aforementioned specification.

Basic Civil Construction Measurement (LEHY-M-II Side Counter Weight)

Item	Specification Content					Remark
Load (kg)	1050	1200	1350	1600		
Specifications Code	P14W	P-16	P-18	P21W	P21D	
Car width AA (mm)	1600	1600	1700	2000	1500	
Depth inside the car BB (mm)	1500	1700	1800	1700	2300	
Sill distance EE from rail center to the car (mm)	853	953	1003	953	1253	1D1G and separate doors.
Door width JJ (mm)	900	900	900	1000	900	Separate door
	1000	1000	1000	1100	1000	Separate door
				1200	1100	Separate door
Door height HH (mm)	2100	2100	2100	2100	2100	
	2200	2200	2200	2200	2200	When the car net height \geq 2300.
	2300	2300	2300	2300	2300	When the car net height \geq 2400.
	2400	2400	2400	2400	2400	When the car net height \geq 2500.
From the car guide rail BG (mm)	1780	1780	1880	2180	1680	
Counterweight guide rails from the WG (mm)	900	1200	1200	1200	1200	When without counterweight safety gear.
	1200	1200	1200	1200	1200	When with heavy safety gear.
Counterweight width WW (mm)	210	210	210	210	210	No counterweight safety gear and speed \leq 3m / s.
	260	260	260	260	260	There counterweight safety gear or speed \geq 3.5m / s.
Shaft type	Single shaft elevator Double shaft elevator	Single shaft elevator Double shaft elevator	Single shaft elevator Double shaft elevator	Single shaft elevator Double shaft elevator	Single shaft elevator Double shaft elevator	Single elevator shaft need to close the top and bottom at the opening of an area of about 2m ² of ventilation holes.
Shaft width AH (mm)	\geq 5420	\geq 5420	\geq 5620	\geq 6220	\geq 5520	No counterweight safety gear, separate door, dual elevator wells. *1
	\geq 2660	\geq 2660	\geq 2760	\geq 3060	\geq 2710	No counterweight safety gear, separate door, step elevators, shaft *1
BH deep inside the shaft (mm)	\geq 2020	\geq 2270	\geq 2320	\geq 2270	\geq 2800	No counterweight safety gear, 1D1G.
Engine room width AM (mm)	\geq 5820	\geq 5820	\geq 6020	\geq 6620	\geq 5920	No counterweight safety gear, separate door, dual elevator wells. *1
	\geq 2960	\geq 2960	\geq 3060	\geq 3260	\geq 2910	Separate door, single staircase shaft. *1
Engine room depth BM (mm)	\geq 3620	\geq 3870	\geq 3920	\geq 3870	\geq 4400	No counterweight safety gear, 1D1G.
Room height (mm)	\geq 2700	\geq 2700	\geq 2700	\geq 2700	\geq 2700	
Pit depth PD (mm)	\geq 1950	\geq 1950	\geq 1950	\geq 1950	\geq 1950	Speed=2.5m/s, Tr \leq 100 time.
	\geq 3050	\geq 3050	\geq 3050	\geq 3050	\geq 3050	Speed=2.5m/s, TR > 100.
	\geq 3250	\geq 3250	\geq 3250	\geq 3250	\geq 3250	Speed=3m/s when.
	\geq 3500	\geq 3500	\geq 3500	\geq 3500	\geq 3500	Speed=3.5m/s when.
Overhead OH (mm)	\geq 5600	\geq 5150	\geq 5150	\geq 5150	\geq 5150	No counterweight safety gear, speed=2.5m/s *2
	\geq 5800	\geq 5700	\geq 5700	\geq 5700	\geq 5700	No counterweight safety gear, speed=3m/s *2
	\geq 6250	\geq 6050	\geq 6050	\geq 6050	\geq 6050	No counterweight safety gear, speed=3.5m/s *2

Values in the table is not with counterweight safety gear, door height = 2100mm, the car in 2300 and the net height = requirements 1D1G separate door, in other case, please refer to the standard civil FIG LEHY-M-II-42.

Basic Civil Construction Measurement (LEHY-M-II Rear Counter Weight)

Item	Specification Content						Remark
Load (kg)	1050	1200	1350	1600	1800	2025	
Specifications Code	P14W	P16W	P18W	P21W	P24W	P27W	
Car width AA (mm)	1600	1800	2000	2000	2100	2100	
Depth inside the car BBB (mm)	1500	1500	1500	1700	1800	1950	
Sill distance EE from rail center to the car (mm)	853	853	853	953	1003	1078	1D1G and separate doors.
Door width JJ (mm)	900	900	1000	1000	1100	1100	
	1000	1000	1100	1100	1200	1200	
		1100	1200	1200			
Door height HH (mm)	2100	2100	2100	2100	2100	2100	
	2200	2200	2200	2200	2200	2200	When the car net height is \geq 2300.
	2300	2300	2300	2300	2300	2300	When the car net height is \geq 2400.
	2400	2400	2400	2400	2400	2400	When the car net height is \geq 2500.
From the car guide rail BG (mm)	1780	1980	2180	2180	2280	2280	
Counterweight guide rails from the WG (mm)	1200	1200	1200	1200	1500	1500	
Counterweight width WW (mm)	210	210	210	210	260	260	No counterweight safety gear and speed \leq 3m/s when.
	260	260	260	260	260	260	With counterweight safety gear or speed > 3m/s when.
Shaft type	Single shaft elevator Double shaft elevator	Single shaft elevator Double shaft elevator	Single shaft elevator Double shaft elevator	Single shaft elevator Double shaft elevator	Single shaft elevator Double shaft elevator	Single shaft elevator Double shaft elevator	Single elevator shaft to close the top and bottom at the opening of an area of about 2m ² of ventilation holes.
Shaft width AH (mm)	\geq 4500	\geq 4900	\geq 5300	\geq 5300	\geq 5700	\geq 5700	Double elevator shaft *1
	\geq 2200	\geq 2400	\geq 2600	\geq 2600	\geq 2800	\geq 2800	Single elevator shaft *1
BH deep inside the shaft (mm)	\geq 2300	\geq 2300	\geq 2300	\geq 2500	\geq 2600	\geq 2750	Without counterweight safety gear.
	\geq 2350	\geq 2350	\geq 2350	\geq 2550	\geq 2650	\geq 2800	With counterweight safety gear.

Basic Civil Construction Measurement (LEHY-M-II Rear Counter Weight)

Item	Specification Content						Remark
Engine room width AM (mm)	\geq 5000	\geq 5200	\geq 5550	\geq 5550	\geq 6100	\geq 6100	Double elevator shaft.
	\geq 2700	\geq 2700	\geq 2850	\geq 2850	\geq 3200	\geq 3200	Single elevator shaft.
Engine room depth BM (mm)	\geq 3850	\geq 3900	\geq 3900	\geq 4100	\geq 4300	\geq 4450	Without counterweight safety gear.
	\geq 3950	\geq 3950	\geq 3950	\geq 4150	\geq 4350	\geq 4500	With counterweight safety gear.
Room height (mm)	\geq 2500	\geq 2500	\geq 2500	\geq 2500	\geq 3000	\geq 3000	
Pit depth PD (mm)	\geq 1950	\geq 1950	\geq 1950	\geq 1950	\geq 2100	\geq 2100	Speed=2.5m/s, and Tr \leq 100 time.
	\geq 2850	\geq 2850	\geq 2850	\geq 2850	\geq 2850	\geq 2850	Speed=2.5m/s, and the TR > 100.
	\geq 3000	\geq 3000	\geq 3000	\geq 3000	\geq 3000	\geq 3000	Speed=3m/s, and when Tr \leq 100.
	\geq 3500	\geq 3500	\geq 3500	\geq 3500	\geq 3650	\geq 3650	Speed=3m/s, and the TR > 100.
	\geq 3200	\geq 3200	\geq 3200	\geq 3200	\geq 3200	\geq 3200	Speed=3.5m/s, and Tr \leq 100 time.
	\geq 3750	\geq 3750	\geq 3750	\geq 3750	\geq 3900	\geq 3900	Speed=3.5m/s, and the TR > 100.
	\geq 3950	\geq 3950	\geq 3950	\geq 3950	\geq 4200	\geq 4200	Speed=4m/s, and Tr \leq 100 time.
	\geq 3950	\geq 3950	\geq 3950	\geq 3950	\geq 4200	\geq 4200	Speed=4m/s, and the TR > 100.
Overhead OH (mm)	\geq 5150	\geq 5150	\geq 5150	\geq 5150	\geq 5400	\geq 5400	No counterweight safety gear and speed=2.5m/s when. *2
	\geq 5700	\geq 5700	\geq 5700	\geq 5700	\geq 5950	\geq 5950	No counterweight safety gear and speed=3m/s when. *2
	\geq 6050	\geq 6050	\geq 6050	\geq 6050	\geq 6300	\geq 6300	No counterweight safety gear and speed=3.5m/s when. *2
	\geq 6450	\geq 6450	\geq 6450	\geq 6450	\geq 6700	\geq 6700	No counterweight safety gear and speed=4m/s when. *2
	\geq 5400	\geq 5550	\geq 5650	\geq 5900	\geq 5800	\geq 5900	With counterweight safety gear, speed=2.5m/s, and Tr \leq 100 time. *2
	\geq 5150	\geq 5250	\geq 5400	\geq 5650	\geq 5550	\geq 5600	With counterweight safety gear, speed=2.5m/s, and the TR > 100. *2
	\geq 5700	\geq 5700	\geq 5700	\geq 5800	\geq 5950	\geq 5950	With counterweight safety gear and speed=3m/s when. *2
	\geq 6150	\geq 6200	\geq 6350	\geq 6550	\geq 6500	\geq 6600	With counterweight safety gear, speed=3.5m/s, and TR \leq 100. *2
	\geq 6050	\geq 6050	\geq 6050	\geq 6200	\geq 6300	\geq 6300	With counterweight safety gear, speed=3.5m/s, and the TR > 100. *2
	\geq 6450	\geq 6450	\geq 6500	\geq 6750	\geq 6700	\geq 6700	With counterweight safety gear and speed = 4m/s when. *2

Values in the table is not with counterweight safety gear, door height = 2100mm, the car in 2300 and the net height = requirements 1D1G separate door, in other case, please refer to the standard civil FIG LEHY-M-II-42.

Basic Civil Construction Measurement (LEHY-H)

Item	Specification Content				Remark
Load (kg)	1200	1350	1600	1800	
Car width AA (mm)	1800	2000	2000	2100	
Depth inside the car BB (mm)	1500	1500	1700	1800	
Sill distance EE from rail center to the car (mm)	858	858	958	1008	
Door width JJ (mm)	1000	1100	1100	1100	
Door height HH (mm)	2100	2100	2100	2100	
From the car guide rail BG (mm)	1980	2180	2180	2280	
Counterweight guide rails from the WG (mm)	1500	1500	1500	1500	
Width WW counterweight guide rails (mm)	260	260	260	310	TR \leq 150m not configured with weight security gear.
	260	260	310	310	TR > 150m when not configured with weight security gear.
	310	310	310	310	Configured with weight security gear.
Shaft type	Through shaft	Through shaft	Through shaft	Through shaft	
Shaft width AH (mm)	\geq 5100	\geq 5500	\geq 5500	\geq 5700	When through shaft (double elevator when the shaft).
	\geq 2300	\geq 2300	\geq 2500	\geq 2650	TR \leq 150m not configured with weight security gear.
BH deep inside the shaft (mm)	\geq 2320	\geq 2320	\geq 2570	\geq 2670	TR > 150m when not configured with weight security gear.
	\geq 2400	\geq 2400	\geq 2600	\geq 2700	TR \leq 150m and configured with weight security gear.
	\geq 2420	\geq 2420	\geq 2620	\geq 2720	TR > 150m and when configured with weight security gear.
Engine room width AM (mm)	\geq 5550	\geq 5850	\geq 5850	\geq 6000	When through shaft. *3
	\geq 3900	\geq 3900	\geq 4100	\geq 4250	TR \leq 150m not configured with weight security gear.
Engine room depth BM (mm)	\geq 3920	\geq 3920	\geq 4170	\geq 4270	TR > 150m when not configured with weight security gear.
	\geq 4000	\geq 4000	\geq 4200	\geq 4300	TR \leq 150m and configured with weight security gear.
	\geq 4020	\geq 4020	\geq 4220	\geq 4320	TR > 150m and when configured with weight security gear.
Pit depth PD (mm)	\geq 5300	\geq 5300	\geq 5300	\geq 5500	TR \leq 150m time.
	\geq 5500	\geq 5500	\geq 5500	\geq 5500	TR > 150m time.
Overhead OH (mm)	\geq 6800	\geq 6800	\geq 6800	\geq 6800	TR \leq 150m time.
	\geq 7200	\geq 7200	\geq 7200	\geq 7200	TR > 150m time.

- 1 When the ITS-21, ITS-2100, as group control of each elevator has inconsistent intermediate stops, non-standard design is required.
- 2 Main landing cannot be the top end landings.
- 3 When single shaft elevator is running, the noise in the car may be loud, subject to technical staff for the calculation and prediction.
- 4 Single elevator shaft need to open at the top and bottom vents an area of approximately 2m².



Note: *1 Double shaft elevator shaft is standard, recommended using multiple shaft elevator. Reference to double shaft elevator data when extended to three elevators (or more than three elevators) shaft.
*2 If configured with air conditioning, the minimum height is required to increase the top 300mm; if configured fan enclosures, the top height reference standard civil FIG LEHY-M-II-42.
*3 Top height values correspond to the car net height 2300mm, and the selected case = 200mm car roof thickness, the net height elevation when in the car, the top height should be elevated accordingly.



SAFETY AND SECURITY CREATE HARMONY

Technology Changes Life,
Scientific Intelligence Leads The Future,
Shanghai Mitsubishi Elevator Will Be There For You Always.

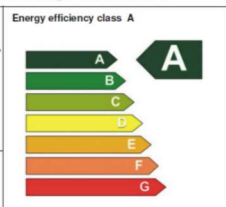
For sales, installation, maintenance service enquiries, complaints and suggestions,
please call 24 hours service supervision hotline: **8008203030**

Lift energy efficiency certificate according to VDI 4707 Part 1		
Manufacturer:	Shanghai Mitsubishi Elevator Co., Ltd.	Energy efficiency class A 
Location:	No. 811 Jiangchuan Road, Minhang Development Zone, Shanghai 200245, P.R. China	
Lift model:	LEHY-M-II	Nominal demand per year for rated values as shown: 22,046 kWh
Lift type:	Passenger Lift	
Serial number:	13N2M16-000-1	
Rated load:	1,600kg	
Rated speed:	4 m/s	Date: 21.04.2014 Reference: VDI 4707 Part 1 (Issue 03-2009)
Operating days per year:	365	
Standby demand:	175 W Energy demand class C	Label No: 0214501
Specific travel demand:	0.414 mWh/(kg·m) Energy demand class A	
Usage category 5 according to VDI 4707 Comparisons of energy efficiency classes are possible under equal usage only.		
Valid until: 20.04.2017		

