

Shanghai Mitsubishi Elevator Co., Ltd.

Address: No. 811 Jiangchuan Road, Minhang, Shanghai, China

Tel : +86-21-24083030/64303030

Fax : +86-21-24083088

Post: 200245

Overseas Business

Tel : +86-21-24083482

Fax : +86-21-24083488

e-mail : overseasbiz@smec-cn.com



www.smeccn.com



Specifications subject to change without notice

Printed in Jun. 2016 (GB-E)



Flexible for Changes, Easy Riding
Providing Trustworthy Quality with Security and Confidence

LEHY-III B

Compact Machine Room Hospital Elevator

Specially Designed for Hospital Environment

SMEC LEHY-III B Hospital Bed Elevator is designed to meet the requirements for using in special environment of hospital to the maximum extent. User-friendly car design, simple and bright, combined with a large number of antibacterial materials, creating a clean and comfortable space for operation. Complement to modern medical environment and facilities in every way with harmonious unity. Creating a caring and comfortable space for the patients.

3 Major Concepts

LEHY-III B Compact Machine Room hospital elevator is designed for hospital environments, combined variable voltage variable frequency (VVVF) speed control technology, permanent magnet synchronous (PM) traction machine technology, intelligent power module (IPM) technology and data network control technology, and many other advantages of science and technology of Mitsubishi. Adhering to the consistent technical advantages of Mitsubishi, LEHY-III B has made a perfect integration of intelligence, comfort, safety, energy-saving, delicacy, disturbance rejection and other professional features, providing hospital elevator with perfect ride quality. LEHY series Compact Machine Room hospital elevator has obtained world-wide acclaim and been highly acknowledged by major professional hospitals.



Professional Quality

Humanized Design

Antibacterial Car

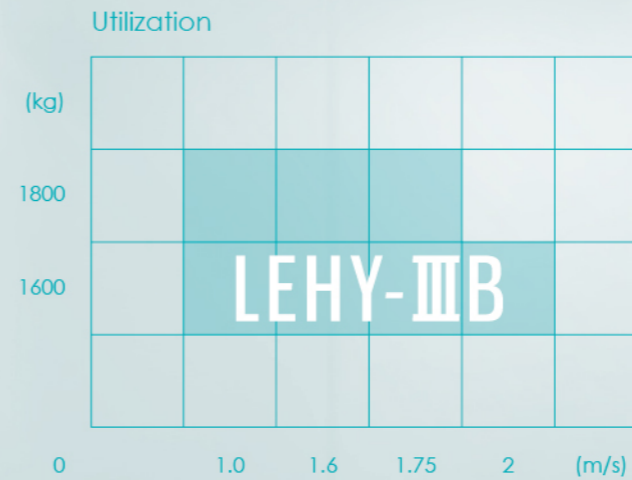

5 Breakthroughs	P.3
5 Innovations	P.5
Safe and Comfort Configuration	P.7
Antibiotic Decoration Part	P.9
A new generation of Decoration system	P.10

Antibacterial Car Design	P.11
Design of Car Roof	P.12
Car Operation Panel	P.14
Landing Display and Landing Call	P.17
Hall Design	P.19
LCD Display Series	P.21
Corresponding Material	P.22

Feature List	P.23
--------------	------

Civil Construction Table	P.25
--------------------------	------

Basic Specifications	P.26
----------------------	------

General

Design

Functions

Civil

Specifications

Traction Machine Absolute Upgrade

The new generation PM synchronous traction machine with high performance uses high quality rare earth material and PM body positioning technique with high precision, meanwhile it comprehensively uses motor techniques such as separate punching and riveting iron core and auto integral coil, which not only makes traction machine output more efficiency, less energy consumption, more peaceful and stable, but also makes traction machine has shorter axle distance and more compact structure; The latest large-scale brake plate and disk brake with low noise are adopted, which are safer, more reliable and more durable, ensuring that brake noise can be significantly reduced while outputting brake torque with abundant safety.

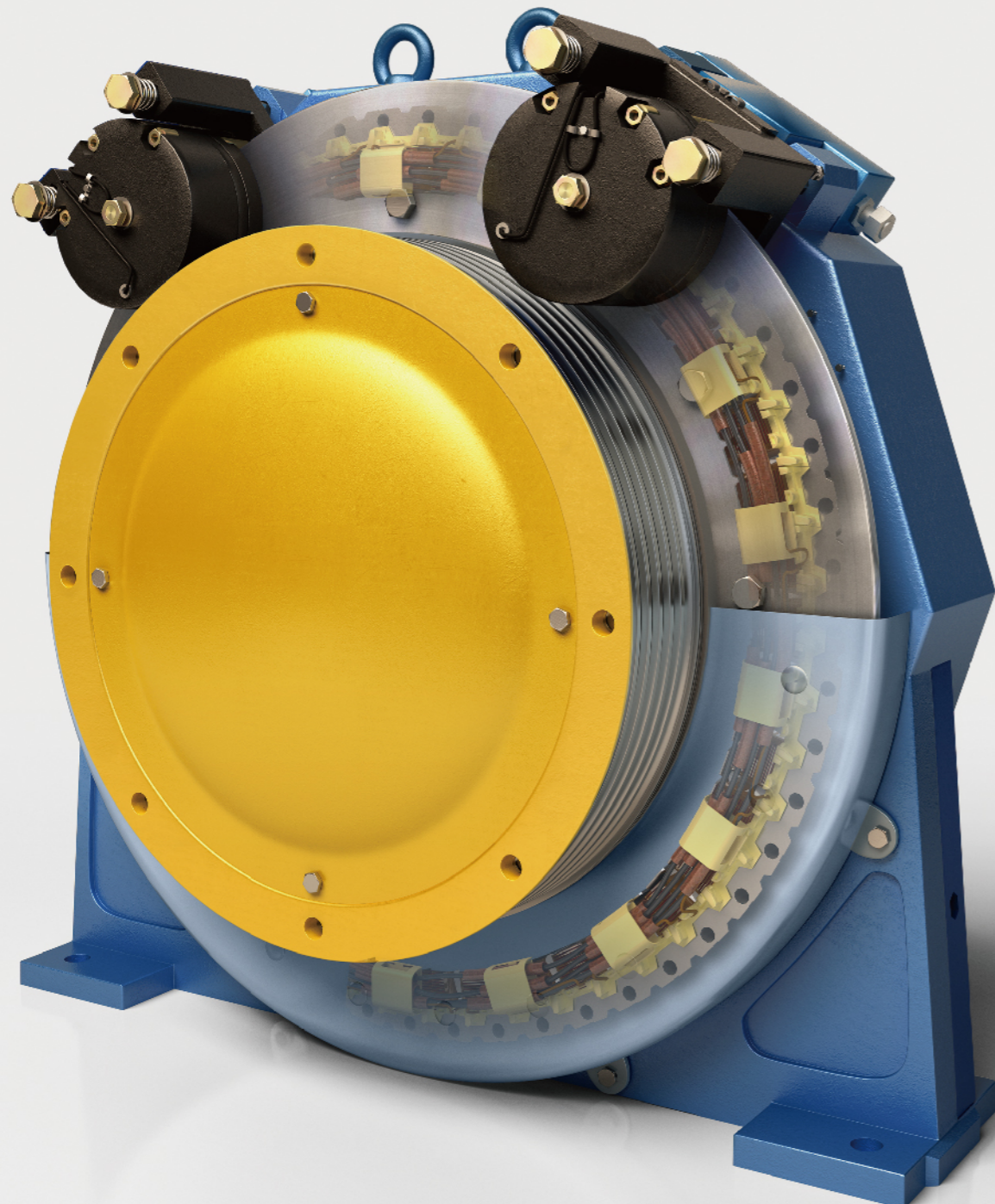

All-digit Intelligence Power System

It utilizes all-digit control intelligent DC-DC power as the substitution for three-phase power transformer to provide power for elevator control system. New power system is not only more stable and reliable, invulnerable to grid fluctuation, but also consume less energy, with higher efficiency and more comprehensive protection.

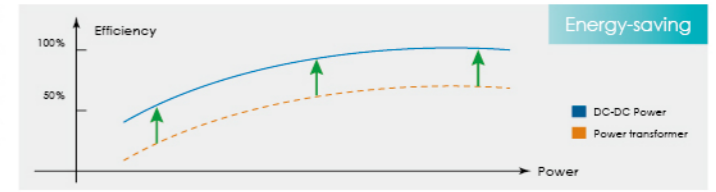

Mute Brake Control Technology

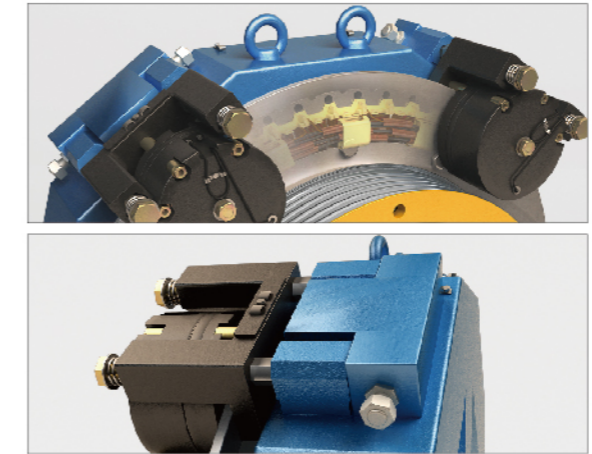

Compared to traditional open-loop voltage control, more accurate closed-loop current control mode is now employed to control the action speed and braking torque at all stages of the brake. This has remarkably reduced the noise from the brake during action and improved the comfort of the passengers while taking the elevators.

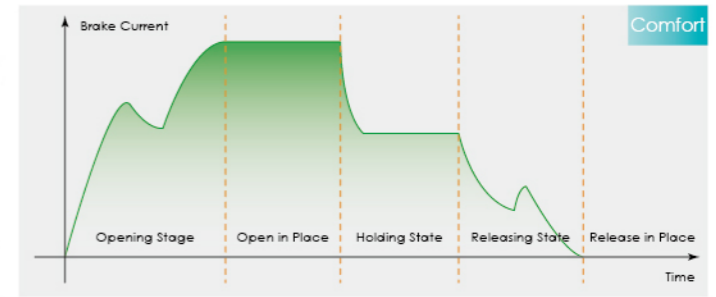

The Latest Generation of High-power Module

Take the lead in employing the sixth generation of high-power module system in the industry. Multiple fast protection circuit can better protect the power module, further improving the reliability of the drive system. Meanwhile, the drive control circuit of power module connects with the power module by direct plugging, further enhancing the system's anti-jamming ability.

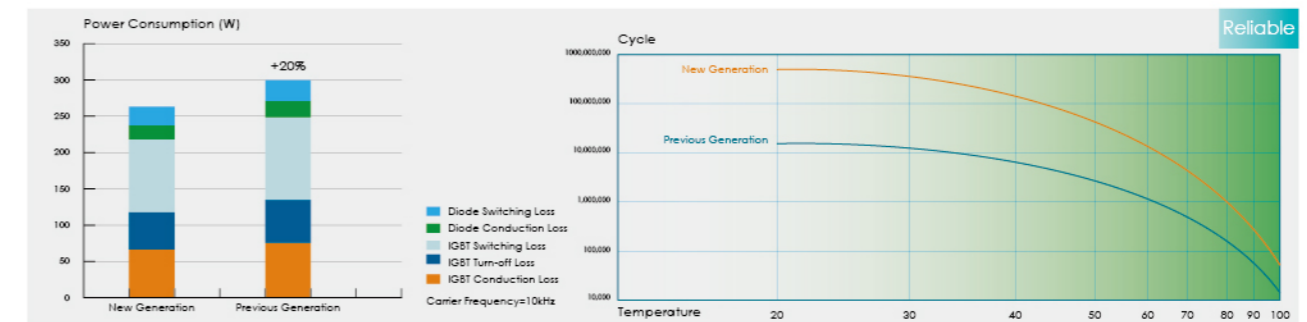

High-performance and Intelligent CPU Control System

Apply new generation of high-performance CPU technology and PCB system architecture and realize elevator's main control system with multi-chip architecture of motor drive, elevator control management, elevator communication and FPGA logic control. Cooperation work of multiple CPUs has greatly improved the elevator system performance. The redundancy protection with multiple CPUs and the FPGA hardware monitoring have improved system stability and security.

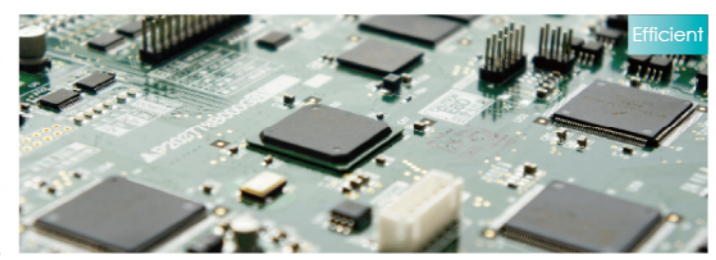

General

Design

Functions

Civil

Specifications

Reliable and Comfortable

AC VVVF Speed Regulation Control Technology, Full Digital Control Technology

Adhering to the philosophy of steadily and slowly releasing of profound knowledge and constantly using latest technologies and components in VVVF drive of elevators enable Shanghai Mitsubishi VVVF speed regulation technology to develop rapidly toward high performance, high reliability, digitization and miniaturization. Employing space vector pulse width modulation (SVPWM) technology to realize elevator speed regulation, taking the lead in adopting international latest sixth generation of high-power module, 32-bit high speed digital signal controller (DSC) and large scale integrated circuit and other advanced electrical components, enabling the elevator to accurately regulate the motor rpm completely according to optimum speed variation curve and operate following the perfect speed curved optimized according to modern ergonomics principle. These have realized full digital control and motor drive in true sense and enabled the elevator run smoothly, safely and efficiently.

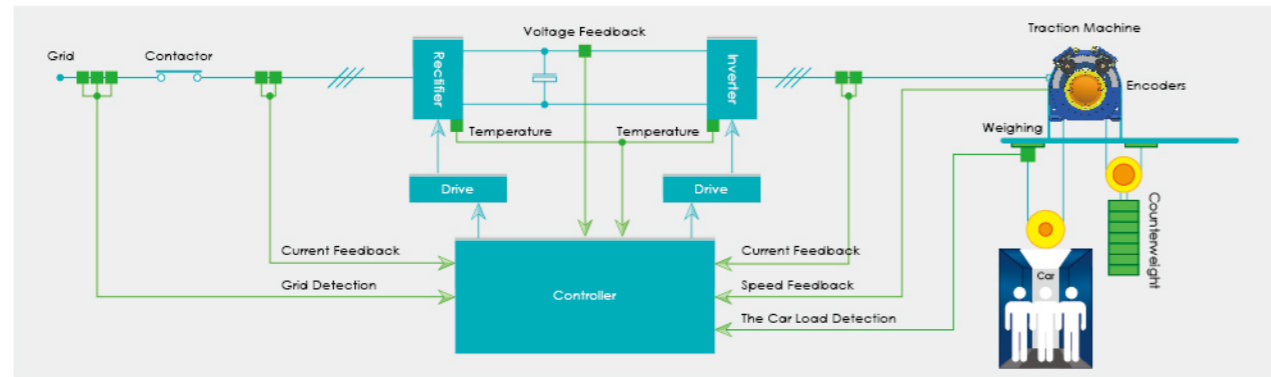

High-speed Network

Data Network Control Technology

Data network control technology based on CANBUS (Field bus) features high communication rate, large data volume. Independent microprocessors are used separately in elevator car command controller, floor indicators inside the car, door machine controller, each landing button and floor indicators and various subsystems. The communication between the various subsystems needs only a few signal lines. This has greatly improved system reliability, electromagnetic interference immunity and flexibility, and reduced the maintenance costs.

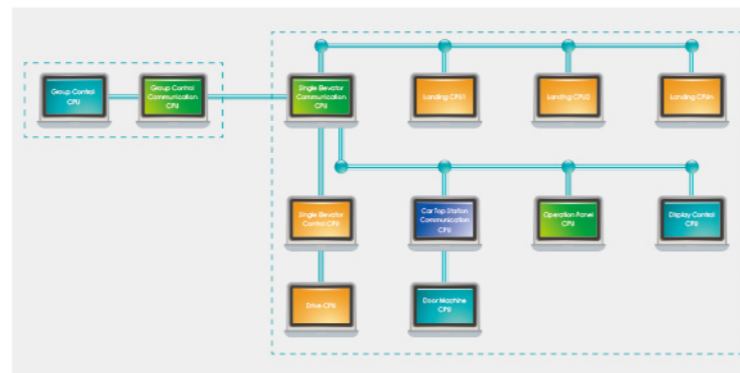

Green and Energy-saving

Energy Feedback Technology (Optional)

Highly energy-saving energy feedback technology based on dual-PWM control can feed the renewable green electric energy, which was consumed through energy consumption resistors, back to the grid without pollution. This can save more than 30% energy compared to common VVVF elevators on average, and so to meet relevant national power quality standards.

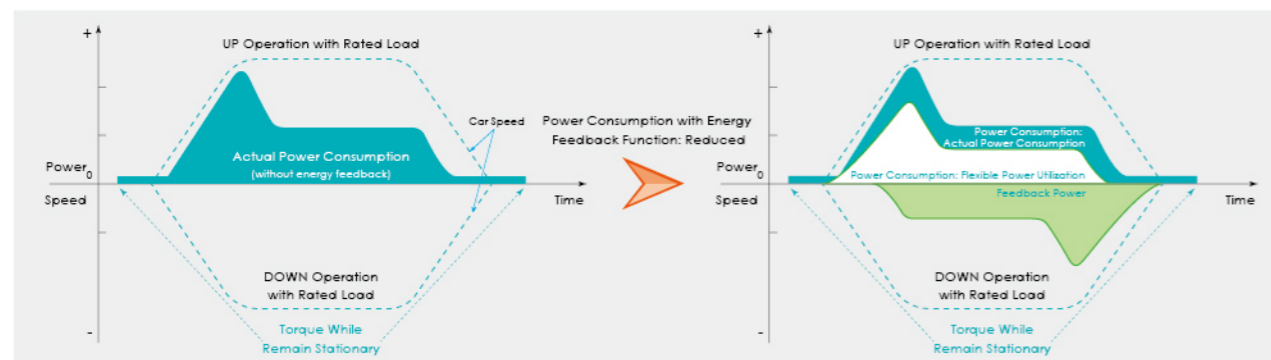

High Adaptability

Really Small Machine Room Design

LEHY-III adopts really small machine room design with the machine room size equal to shaft. This saves machine room space, improves building utilization rate, allows more free building design, and compared to traditional machine room, provides more convenient and safe maintenance of the traction machine, control cabinet, over speed governor and other components.

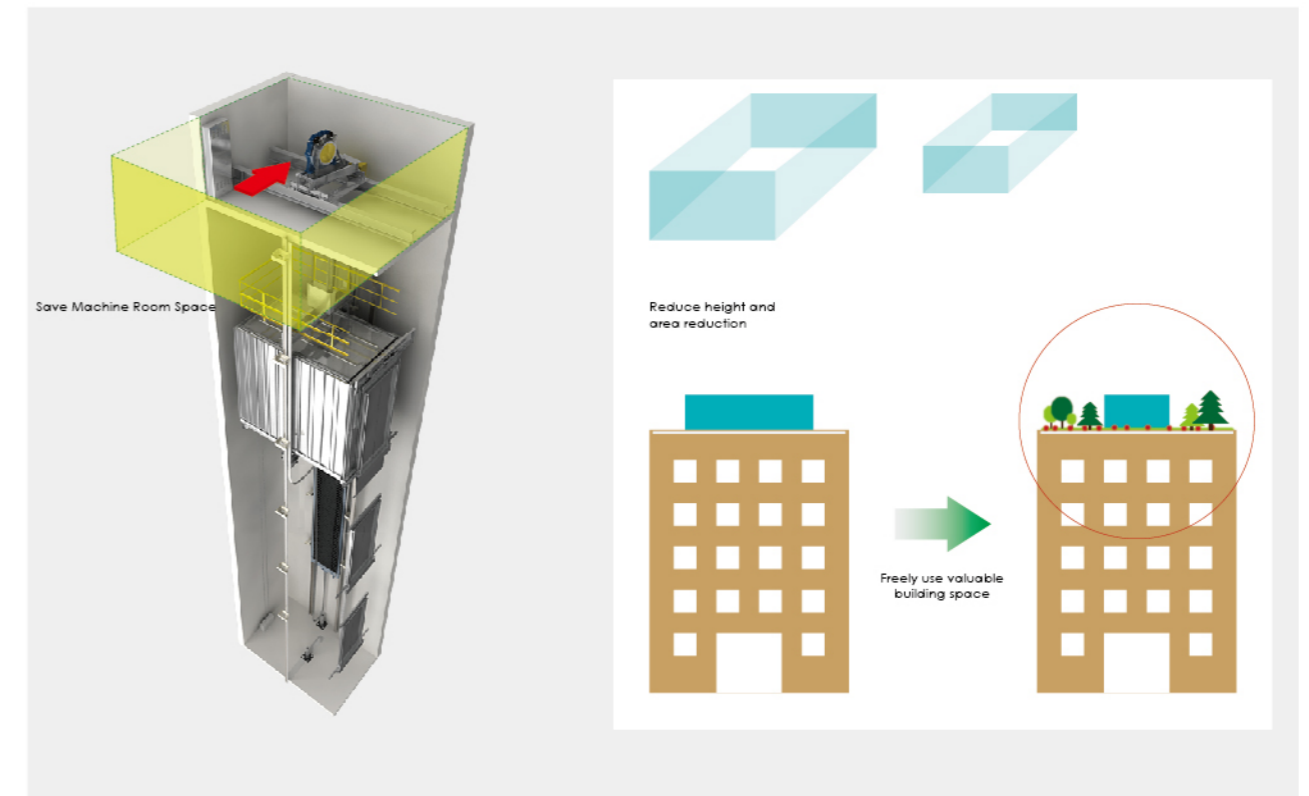

Efficient Group Control

Intelligent Group Control System (Optional)

ITS-21, ITS-2100 group control systems use a high-performance CPU processor for computing and achieving high-speed processing of complex algorithms. High-speed data network has effectively improved the system throughput and scalability. Expert system, fuzzy logic technology and neuron technologies are adopted. Dispatching plan can be given in an intelligent way according to different traffic conditions. This can substantially reduce passengers' waiting time and riding time and reduce elevator operation energy consumption throughout the building by reducing invalid elevator operation.

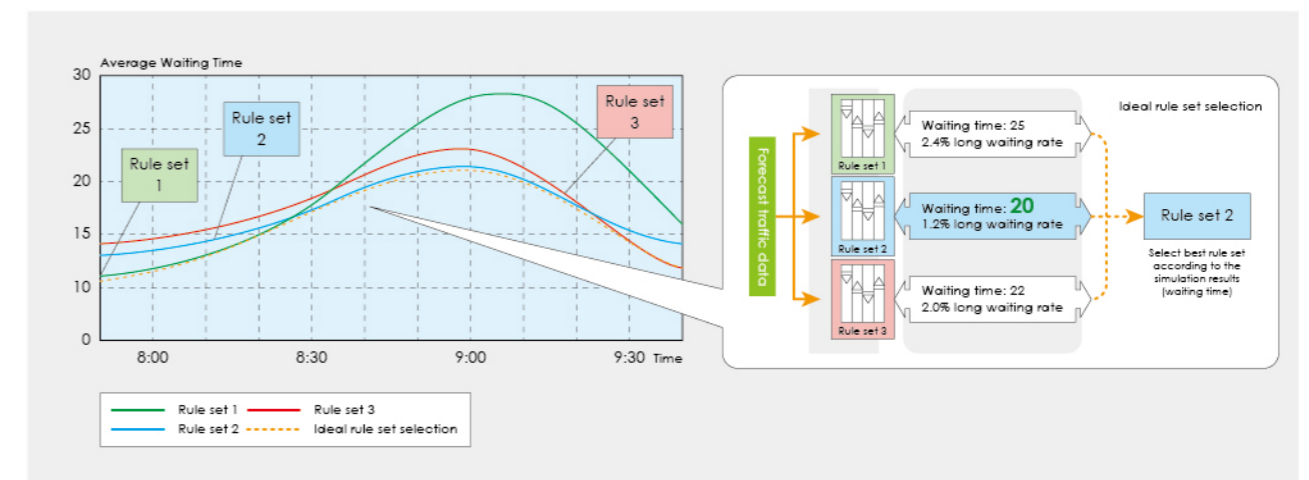

Safe and Comfort Configuration



Multi-beam Safety Edge (MBS)

Safety edge with multi-beam. Provide double protection by multi-beam and safety edge. During door closing, when a passenger or object is detected, the doors will open again. (Standard)

Extended Door-open Button (DKO-TB)

By pressing this button, you can keep the elevator door open for a longer time to facilitate the access of passengers within the hospital. (Standard)



False Call Cancelling – Manual (FCC-P)

If the wrong car button is pressed, it can be canceled by quickly pressing the same button again twice. (Optional)



Voice Announce Device (AAN-S)

In case of car overload, control operation during disaster or misuse, etc., the speech unit will remind the passengers by broadcasting about how to deal with the emergency, so that to mitigate and eliminate passengers' confusion and anxiety. (Optional)



Car Arrival Chime (AECC)

4-5 seconds prior to the arrival of elevator at the call floor, the car arrival chime will prompt the passenger that the car is about to arrive at the destination floor. (Optional)

Barrier-free Design

To facilitate the ride of passengers with disabilities or reduced mobility by setting full-height mirror, handrails and wheelchair control panel inside the car.



Power Failure Emergency Landing Device (ELD)

When normal power supply breaks, this device will supply power to move the car to the nearest floor, level and open the doors, and allow the passengers to leave safely. (Optional)

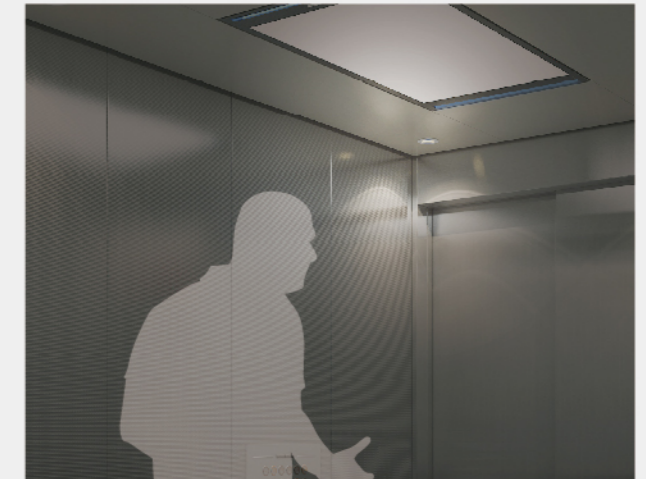

Elevator car video surveillance feature (ITV)

By placing cameras inside the car, you can monitor the status of car from control room, thereby suppressing crime, as well as playing certain role in early detection of the accident. (Optional)



Car Ceiling | Air Purification | Anti-bacterial Collision-resistant Handrail | Non-slip Flooring | Scratch-proof Car Wall

Car Ceiling Dimmable Lighting Air Purification



Car ceiling model: ZCL-GN01

Lighting effect of LGP is soft and even, and may not bring discomfort of glaring to the patient and is also durable with stable lighting effects and hard for fouling.

Air purification and ventilation unit is set at center of car ceiling (at the blue outlet), which can effectively alleviate the sweltering when crowded; at the same time, the using of a light hydrogen ion sterilization technology can effectively kill bacteria in the air inside the car, reducing the risk of spreading germs.



Through the test by the laboratory of Shanghai Environmental Protection Product Quality Supervision and Inspection Station, within the closed space of 30 cubic meters, with continuous operation of the air purification device adopted by this car, the purification efficiency on white Staphylococcus has reached 80%, far more higher than the requirements of 50% for the performance of air purifier in GB GB21551.3 - Special Requirements for Testing of Household and Similar Electrical Appliances Antibacterial, Sterilization, Purification Air Purifier.

Handrails Antibacterial Collision-resistant

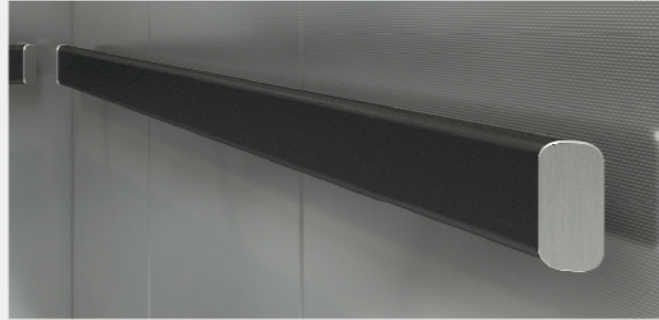

Handrail model: ZYH-SP01

The handrail dimensions are even bigger, which can protect the car wall more effectively, being covered in a polyurethane buffer layer, which can effectively slow the discomfort to the patient that may caused by collision of the hospital beds with car wall.

Highly efficient antimicrobial silver ions have been added to the polyurethane buffer layer on the handrail surface, which can effectively kill bacteria on handrail surface, reducing the risk of spreading germs.

Flooring Non-slip Durable

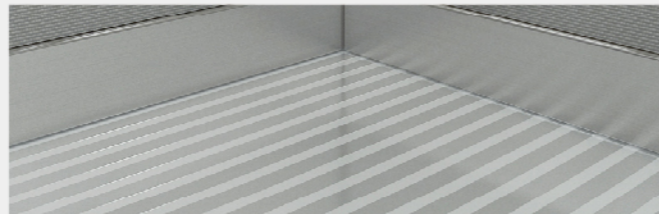

The full stainless steel flooring, designed with optimized lateral bump texture, can greatly reduce the risk of patients' slipping inside the car. Taking into account both the appearance and the anti-slip effect, the full stainless steel flooring is durable and won't easily be deformed and warped due to long-term use.

Car Wall Scratch-proof



Color No.: ZYH-001

The selection of lens embossed stainless steel is with higher surface hardness, which can effectively prevent the car wall against the scratches from the access of medical devices.

A new Generation of Decoration System

Universal decoration system applies to all LEHY elevators of Shanghai Mitsubishi, including LEHY-III, LEHY-MRL, LEHY-M-II, LEHY-H and etc. On the basis of full preliminary surveys and demand collection analysis, the flexibility and responsiveness of the brand new developed decoration configuration are enhanced greatly, providing the customers with choices of different grades and styles.



Easy to install Wall-mounted Call

Call without bottom box does not require reservation of rectangular holes on the wall but small round holes on the wall for installation. The construction is easier and the installation is more convenient.

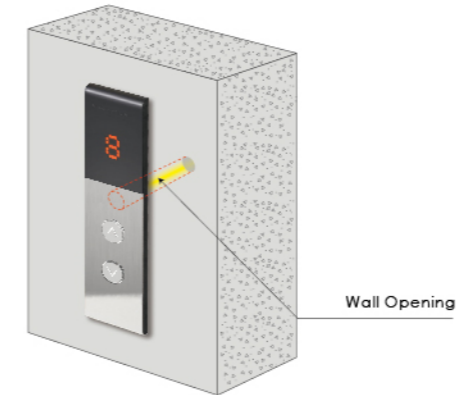

Easily Recognizable Micro-light Buttons

Micro-light design for standby status of buttons improves the recognition of the button numbers, ensuring that the floor numbers on the buttons may be read fast under dim environment.



Brand new Designed Integrated Cars Apply to a Variety of Architectural Styles



The brand new designed integrated cars apply to a majority of architectural occasions, providing various styles and satisfying diversified customer requirements:

- No additional decoration layer, and saving more space and cost;
- One-time delivery save both time and labour;
- Original quality, safe and secure.

Energy Saving and Environment Friendly LED Lighting

The car roofs of LEHY-III are all changed into LED lighting, which has 5 times longer service life than the traditional fluorescent tubes, saving at least 50% electrical cost and thus greatly reducing the maintenance and use costs.

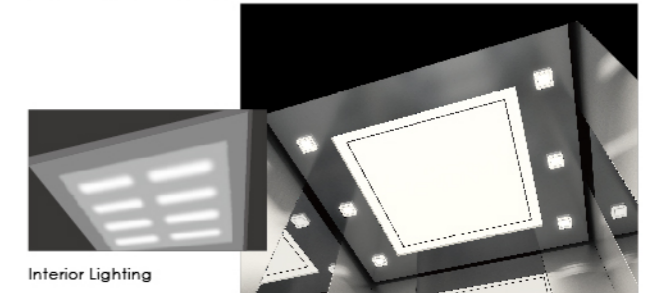

Durable Buttons

The button life reaches up to 5 million times. The reinforced stainless steel button caps designed dedicated for residential elevators adopts anti-falling hook design, which may be resistant to sabotage. (1kg block falling from a height of 0.5m to the button surface for three times and the button can still work normally.)

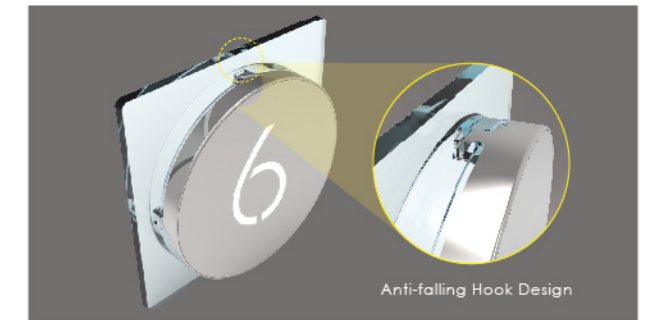



Antibacterial Car Solution

Car Ceiling

ZCL-GN01

Operation Panel

ZCBA02-C110 (Can select other models)

Wheel Chair Operation Panel

ZCBA04-F110

Lighting

Full-LED lighting, central creamy white LGP lighting, dimmable downlight auxiliary lighting at four corners

Air purification and ventilation unit

Air purification and ventilation unit is set at center of car ceiling (at the blue outlet)

Front Wall

Hairline Stainless Steel

Two Sides of the Side Walls and Back Wall

Lentil embossed stainless steel (ZYH-001)

Mirror

Full-body

Car Door

Hairline Stainless Steel

Lintel

Hairline Stainless Steel

Handrails

Single antibacterial handrail on three sides (ZYH-SP01) (Can provide none or select other models)

Floor

Non-slip stainless steel floor (Can select other models)



LEHY-III B Antibacterial Overall Car Design

The R&D team of SMEC has visited hospitals, carried out research interviews to patients, doctors, elevator drivers, care workers and maintenance personnel and gathered first-hand design requirements from users. Based on the market demand, the R&D team has extracted design concept for professional hospital elevator, such as, antibacterial, air purification, central ventilation, collision-resistance and scratch-proof, and so on, so that to deal with the weaknesses of existing products. With careful design, organic integration of product functionality and appearance, SMEC has introduced to our customers the professional hospital elevator solutions with distinctive characteristics.

ZCL-GS06 (Optional)

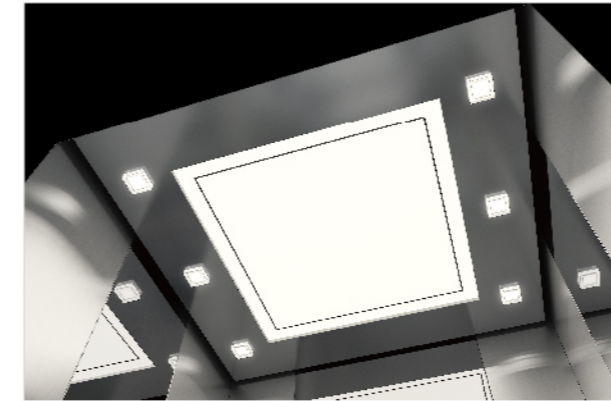

Lighting: central direct lighting; two-side auxiliary lighting;
Material: central milk white printed acrylic lighting board, ambient metallic painting steel sheet, two-side acrylic crystal hanging pieces;
Thickness: 200mm

ZCL-SS06 (Optional)

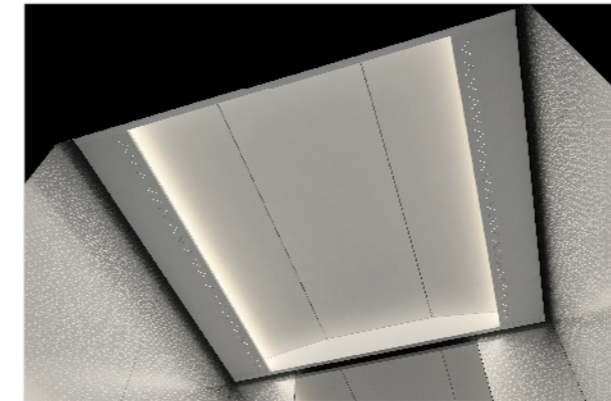

Lighting: two-side warm floodlight lighting;
Material: Painted steel sheet ceiling plate (color code: Y033);
Thickness: 200mm

ZCL-SN03 (Optional)

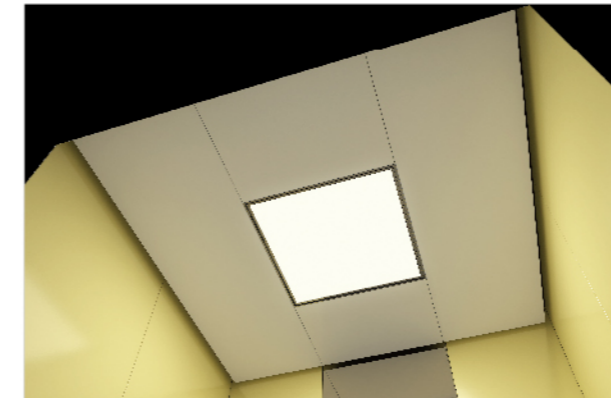

Lighting: central direct lighting;
Material: central milk white light guide plate, peripheral coating steel sheet ceiling (color code: Y033, if other colors are in need, select color in accordance with Shanghai color palette);
Thickness: 100mm

ZCL-CN01 (Empty Car Roof)

By others. (ceiling thickness 100mm).

ZCL-CN08 (Empty Car Roof)

By others. (ceiling thickness 200mm).

ZCL-GN02 (Optional)

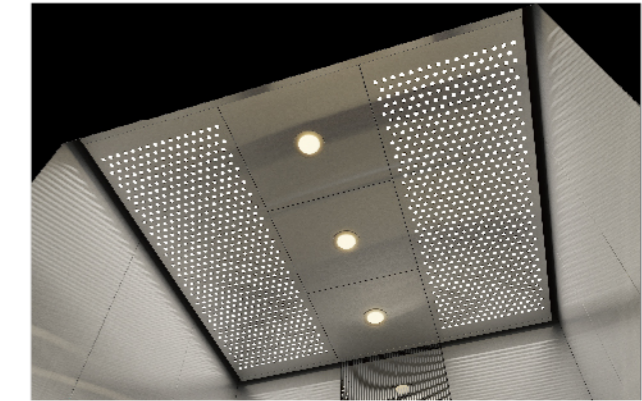

Lighting: central down lamp lighting; two-side lighting board lighting;
Material: Hairline stainless steel ceiling panels;
Thickness: 200mm

ZCL-SS08 (Optional)



Lighting: central direct lighting;
Material: central milk white printed lighting board, two-side coating steel sheet (color code: Y033, if other colors are in need, select color in accordance with Shanghai color palette);
Thickness: 200mm

ZCL-GN01 (Optional)



Lighting: Central main illumination, with lambency downlight at corners as auxiliary lighting;
Material: Central ivory-white light guide plate, with coated steel plate suspended ceiling at corners;
Thickness: 200mm

Note:

All car roofs adopt LED lighting.

Safety windows are optional for car roofs. Consult sales persons for details.

Car Operation Panel

Front Wall Half Height Operation Panel

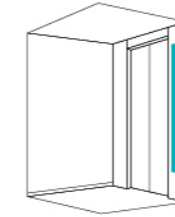

Amber LED, classic and durable.

Stainless Steel Panel

The buttons are exchangeable. The figure shown is A02 button.

ZCB-C110 (Primary)
ZCB-C160 (Auxiliary)



5.7" Color segmented LCD, fine and vivid.

Stainless Steel Panel

The buttons are exchangeable. The figure shown is A11 button.

ZCB-C510 (Primary)
ZCB-C560 (Auxiliary)



5.7" TFT LCD, fine and vivid.

Stainless Steel Panel

The buttons are exchangeable. The figure shown is A13 button.

ZCB-C210 (Primary)
ZCB-C260 (Auxiliary)

Note:
*1 Configurable when front wall width ≥ 250 mm.
*2 The symbol ■ represents the button model; please select the button model from Page 18; it is recommended to select A01~A06 buttons when the parking floors of front wall half-height operation panel exceed 28 floors.
*3 Please refer to Page 21 for LCD.

General
Design
Functions
Civil
Specifications

Human-machine Component Design

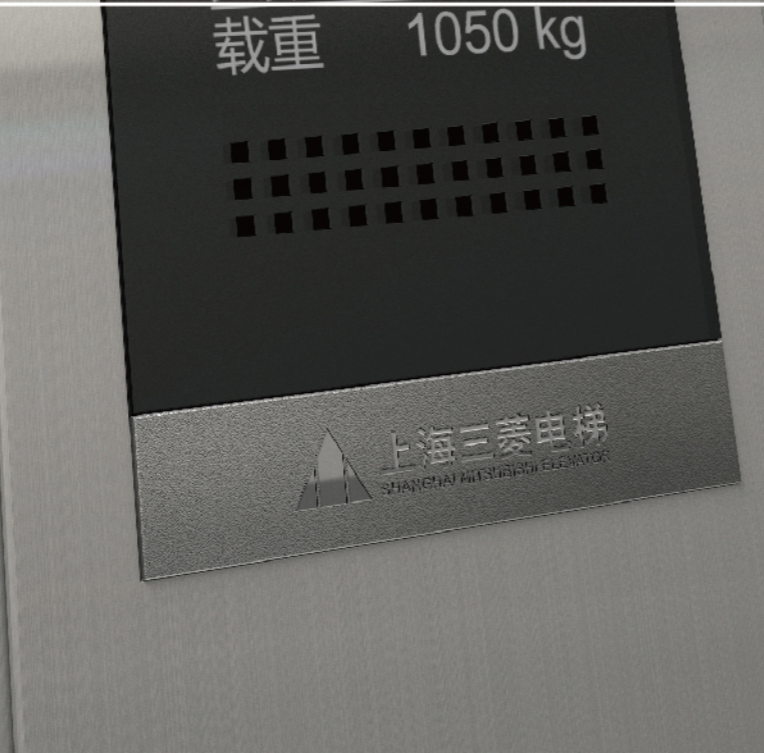
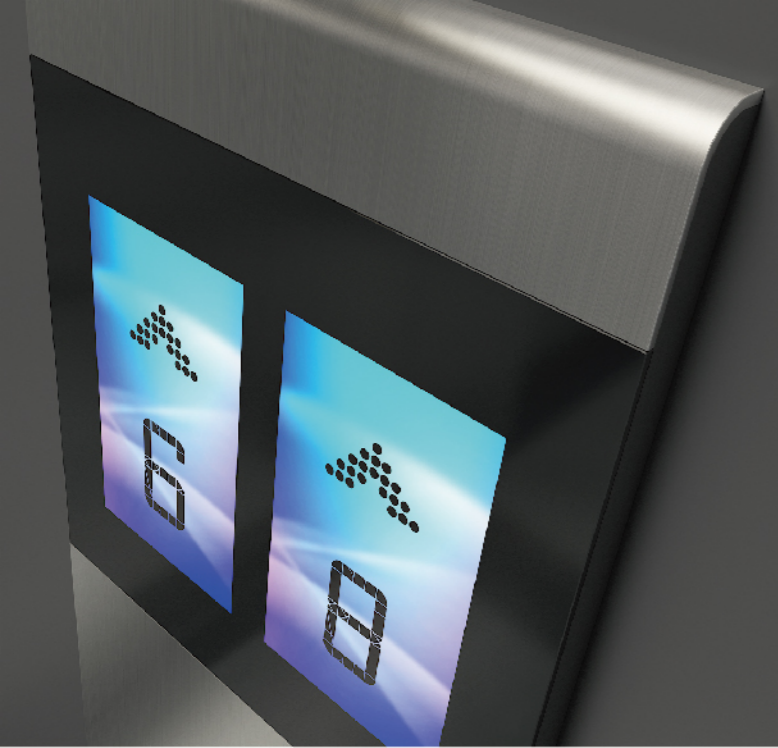

Side Wall Full-height Operation Panel

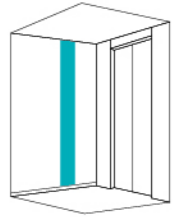

<p>Amber LED, classic and durable.</p> <p>Stainless Steel Panel</p> <p>The buttons are exchangeable. The figure shown is A02 button.</p> <p>ZCB-R110 (Primary) ZCB-R160 (Auxiliary)</p>	<p>5.7" Color segmented LCD, fine and vivid.</p> <p>Stainless Steel Panel</p> <p>The buttons are exchangeable. The figure shown is A11 button.</p> <p>ZCB-R510 (Primary) ZCB-R560 (Auxiliary)</p>	<p>5.7" TFT LCD, fine and vivid.</p> <p>Stainless Steel Panel</p> <p>The buttons are exchangeable. The figure shown is A13 button.</p> <p>ZCB-R210 (Primary) ZCB-R260 (Auxiliary)</p>
---	---	---

Side Wall Full-height Operation Panel Comply with GB/ T24477 Standard

<p>Amber LED, classic and durable.</p> <p>Stainless Steel Panel</p> <p>The buttons are exchangeable. The figure shown is A04 button.*1</p> <p>ZCB-R130 (Primary) ZCB-R180 (Auxiliary)</p>	<p>5.7" Color segmented LCD, fine and vivid.</p> <p>Stainless Steel Panel</p> <p>The buttons are exchangeable. The figure shown is A04 button.*1</p> <p>ZCB-R530 (Primary) ZCB-R580 (Auxiliary)</p>	<p>5.7" TFT LCD, fine and vivid.</p> <p>Stainless Steel Panel</p> <p>The buttons are exchangeable. The figure shown is A04 button.*1</p> <p>ZCB-R230 (Primary) ZCB-R280 (Auxiliary)</p>
---	---	---

Wheel Chair Operation Panel

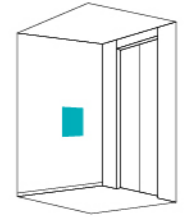

<p>5.7" TFT LCD, fine and vivid.</p> <p>Stainless Steel Panel</p> <p>ZCB-F110 (Primary) ZCB-F160 (Auxiliary)</p>	<p>5.7" TFT LCD, fine and vivid.</p> <p>Stainless Steel Panel</p> <p>ZCB-F130 (Primary) ZCB-F180 (Auxiliary)</p> <p>Comply with GB/ T24477 Standard</p>
--	---

Note:
 *1 Configurable when front wall width <250mm.
 *2 The symbol ■ represents the button model, please select button from Page 18.
 *3 Please refer to Page 21 for LCD.

Note:
 *1 Signal ■ represents the button model. The optional buttons of the operation panel in this page are A04, A05, A06 (complying with GB/T24477 standard). See details in Page 18.
 *2 Please refer to Page 21 for LCD.
 *3 The difference of the appearance of ZCB-F130 and ZCB-F110: the button of the first floor is protruding and the frames of the two sides are black.

Wall-mounted Landing Call

LED Dot Matrix Display

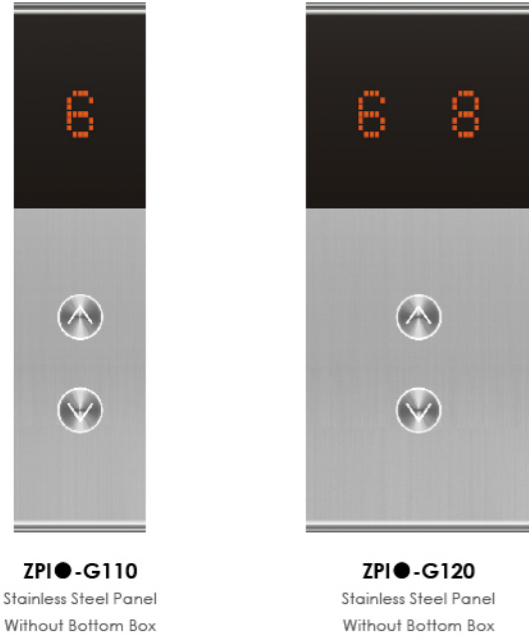

Wall-mounted Landing Call (Without Bottom Box)

Barrier-free design response,
complying with GB/T24477 standard.



Matching Diagram (Respond to the requirements of the handicapped.)
Single elevator and parallel connection calls should be corresponding one by one.

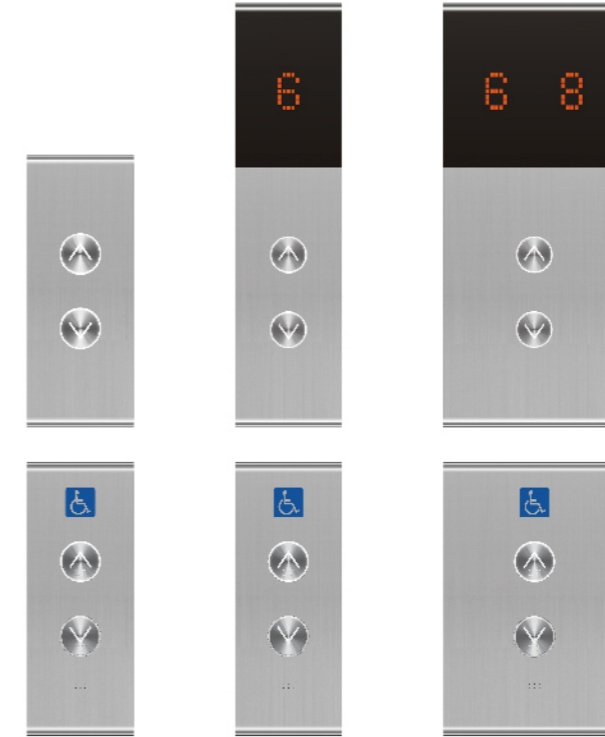

4.3'' Color Segmented LCD



4.3'' TFT LCD

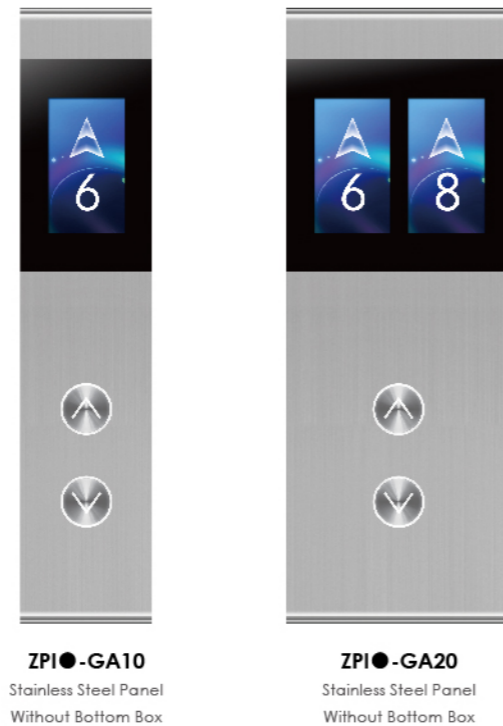

Flexible and Replaceable Button Series

Basic Buttons



A11
Diameter 35mm, Machinery Fine Motion
Standby Micro-light, Stainless Steel Surface

A11	White Light	Flat Words
A12	Orange Light	Flat Words
A13	Blue Light	Flat Words
A14	White Light	Protruded Words with Braille
A15	Orange Light	Protruded Words with Braille
A16	Blue Light	Protruded Words with Braille



A01 *1
Diameter 31mm, Machinery Fine Motion
Standby Micro-light, Stainless Steel Surface

A01	White Light	Flat Words
A02	Orange Light	Flat Words
A03	Blue Light	Flat Words
A04	White Light	Protruded Words with Braille
A05	Orange Light	Protruded Words with Braille
A06	Blue Light	Protruded Words with Braille

Illustration of the Button Samples



White Light Flat Words Orange Light Flat Words Blue Light Flat Words White Light Protruded Words with Braille Orange Light Protruded Words with Braille Blue Light Protruded Words with Braille

Note:
*1 It is recommended to select A11~A16 buttons for hall call buttons when the car operation panel selects A01~A06 buttons.
*2 A01~A06 are not optional for hall call buttons.

Note:
*1 The symbol ● represents the button model; please select button from Page 18;
*2 The symbol ● represents the button model. The optional buttons are A14, A15, A16 (complying with GB/T24477 standard). See details in Page 18.
*3 Required to be used together with ZHB-G010 or ZPI-GX10
*4 Required to be used together with ZHB-G020.
*5 Required to be used together with ZPI-GX20.
*6 If bottom box is needed, contact the sales person for non-standard installation of bottom box. The appearance of the landing indicators with or without bottom box will be consistent.

Hall Door and Jamb

E-102

Narrow Door Jamb
Applicable for wide car, deep car.



Landing Display Call: ZPIA02-G110
Landing Door Material: Painted Steel Sheet
Jamb Material: Painted Steel Sheet

E-302

Bevel (10°) Large Door Jamb
Applicable for wide car, deep car.



Landing Display Call: ZPIA11-GB10
Landing Door Material: Hairline Stainless Steel
Jamb Material: Hairline Stainless Steel

E-312

Curtain Plate Type Bevel (10°) Large Door Jamb
Only applicable for wide car.



Landing Direction Light: ZHLV-H010
Landing Call: ZHBA11-G010
Landing Door Material: Hairline Etched Stainless Steel (ZHY-006)
Jamb Material: Hairline Stainless Steel

E-322

Slant Curtain Plate Bevel (10°) Large Door Jamb
Only applicable for wide car.

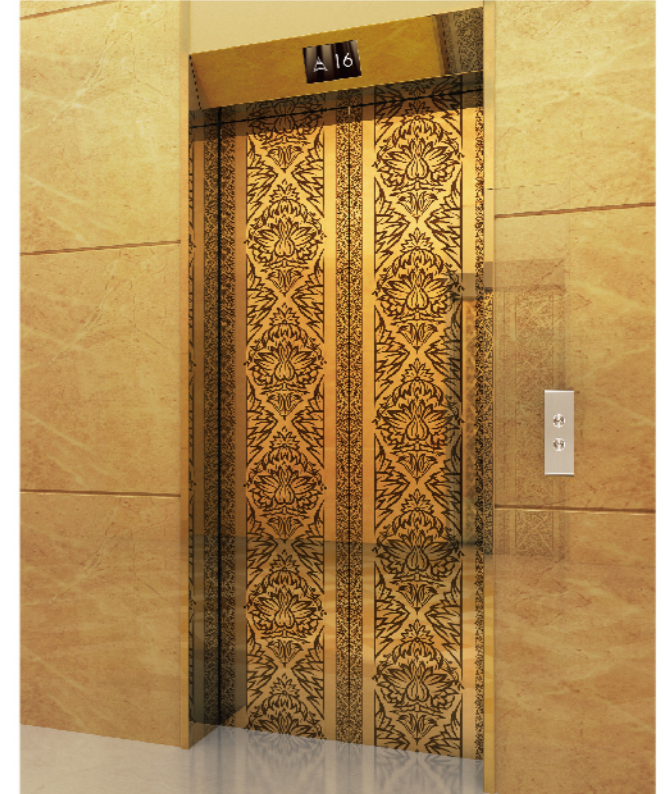

Landing LCD: ZPIH-N301 (Elegant Brown)
Landing Call: ZHBA11-G010
Landing Door Material: Mirror Blasted Double-color Titanium-coated Stainless Steel (ZPF-001)
Jamb Material: Mirror Titanium-coated Stainless Steel (ZDT-002)

Landing Direction Light

Should be used together with the landing call button components referred to Page 17.



ZHLV-H021 Hairline/Mirror Stainless Steel Panels Mist white acrylic of the lighting part	ZHLV-H030 Without Panel Mist white acrylic of the lighting part Precise openings for wall decoration are in need.	ZHLV-R061 Hairline/Mirror Stainless Steel Panels Mist white acrylic of the lighting part	ZHLV-R070 Without Panel Mist white acrylic of the lighting part Precise openings for wall decoration are in need.	ZHLV-R050 Without Panel Mist white acrylic of the lighting part Precise openings for wall decoration are in need.	ZHLV-B031 Hairline/Mirror Stainless Steel Panels Transparent acrylic of the lighting part (engraved and blasted)	ZHLV-B040 Wall-Mounted Type without Bottom Box Transparent acrylic of the lighting part (embedded with mist white indicating blocks)
---	---	---	---	---	--	---

* The above landing direction lights are all LED lighting, which are energy saving and with prolonged service life.
Each model of direction lights provides: white light, warm white light and blue light at your choice.

Diagram of the lighting color of each landing direction light



White Light Warm White Light Blue Light

Color Segmented LCD

Patented LCD technology: innovative interface design, full view, high contrast ratio.

4.3" LCD (For Landing Display)



5.7" LCD (For Operation Panel)



TFT LCD

The new generation of LCD adopts the state-of-the-art hardware driving circuits and finer LCD screens. Adopt also the brand new interface design, endowing common LCD with new vitality, livelier, more vivid and cozier. The typical interface designs of the four styles may comply with the demands of various car decorations.

Horizontal elevator operating indication.
(For operation panel 5.7" / for landing display 8.4")



Glaring Purple Standard



Fragrant Green Residence



Elegant Brown Hotel



Gentle Blue Business Building

Vertical elevator operating indication.
(For landing display call 4.3" / for operation panel 8.4")



Glaring Purple Standard



Fragrant Green Residence



Elegant Brown Hotel



Gentle Blue Business Building

* It is required to designate an interface when ordering the elevator.

Handrail Type



ZYH-SH01
Stainless steel single flat handrail

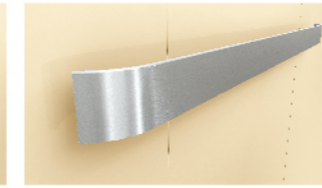

ZYH-FH10
Stainless steel single flat handrail

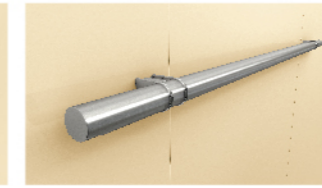

ZYH-RH01
Stainless Steel Round Handrail

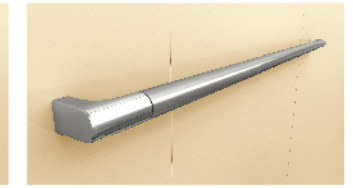

ZYH-RH02
Stainless Steel Round Handrail

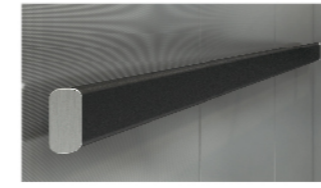

ZYH-SP01
Polyurethane single handrail

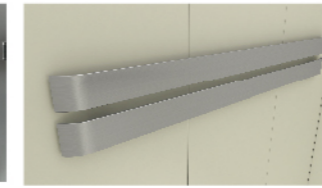

ZYH-FH10
Stainless steel double flat handrails

Parquet Floor

Can also select PVC stone floor, and the color No. is selected according to the Decoration Color Plate of Shanghai Mitsubishi.

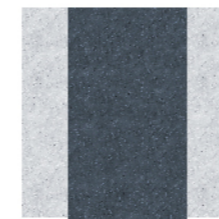

ZPH-027



ZPH-030



ZPH-028

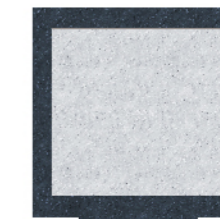

ZPH-023

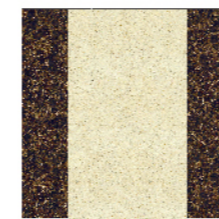

ZPH-026



ZPH-029



ZPH-031

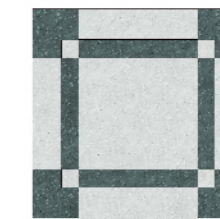

ZPH-014

Project	Specifications	Notes
Car Wall	Painted steel sheet, hairline stainless steel, hairline etched stainless steel, hairline titanium-coated stainless steel, hairline etched titanium-coated stainless steel, mirror stainless steel, mirror etched titanium-coated stainless steel, stainless steel with irregularly-polished lines, titanium-coated stainless steel with irregularly-polished lines, sand-pattern stainless steel, sand-pattern titanium-coated stainless steel, metallic painting steel sheet, laminated steel sheet, Film-mounting steel sheet, Patterned stainless steel	
Car Door	Painted steel sheet, hairline stainless steel, hairline etched stainless steel, hairline titanium-coated stainless steel, hairline etched titanium-coated stainless steel, mirror stainless steel, mirror etched titanium-coated stainless steel, stainless steel with irregularly-polished lines, titanium-coated stainless steel with irregularly-polished lines, sand-pattern stainless steel, sand-pattern titanium-coated stainless steel, metallic painting steel sheet, laminated steel sheet, Film-mounting steel sheet	
Mirror	None, half-height, full height	When door opening is 1D1G.
	None	When the door opening is non-1D1G.
Handrail Type	None, rear wall, two side walls, three sides wall	When selecting self-selected plan for car decoration and the opening type is 1D1G.
	None, two side walls	When selecting self-selected plan for car decoration and the opening type is non-1D1G.
Floor	PVC stone floor, Parquet floor Marble floor	
Landing Door	Painted steel sheet, hairline stainless steel, hairline etched stainless steel, hairline titanium-coated stainless steel, hairline etched titanium-coated stainless steel, mirror stainless steel, mirror etched titanium-coated stainless steel, stainless steel with irregularly-polished lines, titanium-coated stainless steel with irregularly-polished lines, sand-pattern stainless steel, sand-pattern titanium-coated stainless steel, metallic painting steel sheet, F-Design-II	
Jamb	Painted steel sheet, metallic painted steel sheet, hairline stainless steel, hairline titanium-coated stainless steel, mirror stainless steel, mirror titanium-coated stainless steel, stainless steel with irregularly-polished lines, titanium-coated stainless steel with irregularly-polished lines, sand-pattern stainless steel, sand-pattern titanium-coated stainless steel	Applicable when it is E312, E322 when they are center opening doors; Applicable for E102 and E302.
	Painted steel, hairline stainless steel	Applicable for E312 and E322 when they are side opening doors.

Feature	Description	Code	1C-2BC	2C-3M2	3-4C ITS-2	3-8C ITS-2 00
Control and Security Features						
Automatic Landing with Rheostatic Leveling	When the car parks at a station, if the vertical difference between the upper plane of the car sill and that of the landing door sill exceeds predetermined value, the elevator will level automatically.	ARL	☑	☑	☑	☑
Anti-stall Timer	When the traction rope slips or motor stall reaches predetermined time, the elevator will stop.	AST	☑	☑	☑	☑
Brake Redundancy Protection	When a group of brakes fails, the remaining brakes still can realize effective braking of the elevator.	BTUP	☑	☑	☑	☑
Energy Feedback	Feed energy generated during operation back to the grid to save energy.	EFDBK	☑	☑	☑	☑
Electrical Safe Loop Protection	Prevent the elevator from operating once the electrical safety devices connected together in series act.	ESC	☑	☑	☑	☑
Automatic story height measuring	Automatically measure and record story height	FMR	☑	☑	☑	☑
Hand Operation	Inspection operation mode for maintenance personnel.	HAND	☑	☑	☑	☑
Load Weighing Start	The elevator adjusts startup torque according to the car load so as to allow smooth start.	LWS	☑	☑	☑	☑
Over-current Protection	Stop elevator when the current through the rectifier or inverter is detected too high.	OCP	☑	☑	☑	☑
Over-speed Protection	Stop elevator when the running speed is detected over allowable value.	OSP	☑	☑	☑	☑
Over-Temperature Protection	Stop elevator when over temperature of motor is detected.	OTP	☑	☑	☑	☑
Over-voltage Protection	Stop elevator when the voltage across the rectifier or inverter is detected too high.	OVP	☑	☑	☑	☑
Power Failure Protection	Stop elevator when open-phase, undervoltage or other faults of power occurs.	PPF	☑	☑	☑	☑
Power-on Releveling	If the car stops in the range of door area due to power failure, it will relevel to the leveling position after the power is recovered.	PORL	☑	☑	☑	☑
Reversal protection	Stop elevator when it is detected running in reversed direction.	RSP	☑	☑	☑	☑
Selector Correcting	The elevator corrects the selector during operation	SC	☑	☑	☑	☑
Safe Landing	If a car has stopped between floors for some reason, the controller checks the cause, and if it is considered safe to move the car, the car will move to the nearest floor and doors will open.	SFL	☑	☑	☑	☑
Stop Open	The car doors open automatically after the car stops at a floor.	SO	☑	☑	☑	☑
Inverter High-temperature Detect	Stop elevator when inverter high-temperature is detected.	THMF	☑	☑	☑	☑
Terminal Forced Decelerate	If the car runs to the terminal but the speed has not been reduced to specified value, the system will force it to decelerate and thus enable it to level normally.	TSD	☑	☑	☑	☑
Under speed Protection	Stop elevator when the running speed is detected under allowable value.	USP	☑	☑	☑	☑
Operational and Service Features						
Automatic Bypass	When the car load exceeds 80% (adjustable) rated capacity, the elevator does not response hall calls from other floors along its travel.	ABP	☑	☑	☑	☑
Attendant Service	Normal operation of the elevator is conducted by an attendant	AS	☑	☑	☑	☑
Car Computer Back Up Operation	When an abnormality occurs on the car computer, the car stops at nearest floor and the elevator cannot restart.	CCBK	☑	☑	☑	☑
Car Call Cancelling	In automatic operation, when a car has responded to the final car call or landing call in one direction, the system automatically checks and clears remaining car calls from the memory.	CCC	☑	☑	☑	☑
Car Fan Shut Off - Automatic	If there are no calls for a specified period, the car ventilation fan will automatically be turned off to conserve energy.	CFO-A	☑	☑	☑	☑
Car Fan Shut Off - Manual (button type)	The car ventilation fan is turned off by combination buttons on the operation panel.	CFO-B	☑	☑	☑	☑
Car Light Shut Off - Automatic	If there are no calls for a specified period, the car light will automatically be turned off to conserve energy.	CLO-A	☑	☑	☑	☑
Car Light Shut Off - Manual (button type)	The car light is turned off by combination buttons on the operation panel.	CLO-B	☑	☑	☑	☑
Continuity of Service	To ensure normal operation of elevators in a whole group, when a certain elevator cannot respond registered landing calls, it will be excluded from landing call service, and service is provided by other elevators.	COS	—	☑	☑	☑
Elevator Dedicated Air Conditioning	Air conditioning for elevator car.	EAC *1	☑	☑	☑	☑
Self-diagnosis	Diagnose abnormalities and faults occurred during elevator operation.	EFD	☑	☑	☑	☑
Exit Switch	Switch for detecting state of exit	EXIT SW	☑	☑	☑	☑
False Call Cancelling - Automatic	If the number of registered calls is not agree with the number of passengers, it will cancel all calls to avoid unnecessary stops.	FCC-A *2	☑	☑	☑	☑
False Call Cancelling - Manual (car button type)	If the wrong car button is pressed, it can be canceled by quickly pressing the same button again twice.	FCC-P *3	☑	☑	☑	☑
Hall Call Erase - Manual (hall button type)	If the wrong hall calling button is pressed, it can be canceled by quickly pressing the same button again twice.	FHC-P	☑	—	☑	—
Automatic Hall Call Registration	When one elevator cannot take all passengers, the landing button remains registered state, and the system will assign another elevator to provide service.	FSAT	☑	☑	☑	☑
Group Control Backup Service	Maintain service of individual elevators when group control becomes invalid due to failure of the group control controller or failure of communication between the group control and individual stations.	GCBK	—	—	☑	☑
Hall Computer Back UP Operation	When an abnormality occurs on the hall computer, the car stops at nearest floor and the elevator cannot restart.	HCBK	☑	☑	☑	☑
Hospital Emergency - Block Sign	By pressing the Door Open button and the DKO-TB button simultaneously, the elevator will respond only to the car call.	HE-B	☑	☑	☑	☑
Hall Out-of-service Operation	Turn on or shut off the elevator by operating the "RUN/STOP" switch installed on specified floor.	HOS	☑	☑	☑	☑
Independent Service	Using the Independent switch in the operation panel, the car can respond only to car calls without interrupting service.	IND	☑	☑	☑	☑
Non-service to Specific Floor (switch type)	Operating this switch can cancel service to specified floors.	NS *4	☑	☑	☑	☑
Non-service to Specific Floor (car button type)	Cancel service to specific floor by operating buttons on the operation panel and the setting switch.	NS-CB *5	☑	☑	☑	☑
Not Start Operation	When landing call or car call is registered but the car cannot start within predetermined time, it will clear the assigned landing call, reserve the car call, light up the Abnormal lamp, and sound the Abnormal bell.	NST	☑	☑	☑	☑
Next Landing	After the car has arrived at the destination floor, if the car doors cannot open fully, it will close the doors and continue to run to the next floor until the doors can open fully and then restore normal operation.	NXL	☑	☑	☑	☑
Overload Holding Stop	When the car is overloaded, the doors remain open and a buzzer sounds.	OLH	☑	☑	☑	☑
Remote Control Stop	Start or stop the car through the remote control switch.	RCS *6	☑	☑	☑	☑
Return Operation	Operating Return switch to immediate call the car back to specified floor and park there.	RET *6	☑	☑	☑	☑
Secret Call Service (car button type)	Lock certain floors on the operation panel by setting password. The buttons of these specified floors can only be registered after the password is entered on the operation panel.	SCS-B *7	☑	☑	☑	☑
Secret Call Service (IC card type)	The buttons of certain specified floors can only be registered via IC card.	SCS-IC *1	☑	☑	☑	☑
Emergency Operation Features						
Emergency Car Lighting	Immediately provide car lighting when normal lighting power supply breaks.	ECL	☑	☑	☑	☑
Earthquake Emergency Return (S-wave)	When S-wave earthquake detector acts, the car immediately parks at the nearest floor with door opened.	EER-S	☑	☑	☑	☑
Power Failure Emergency Landing Device	When normal power supply breaks, this device will supply power to move the car to the nearest floor, level and open the doors, and allow the passengers to leave safely.	ELD *8	☑	☑	☑	☑
Alarm Bell	Press this alarm bell in emergency. The bell and interphone will sound.	EMB	☑	☑	☑	☑
Fire Emergency Return	When the Fire Emergency Return switch acts, all landing calls and car calls are cancelled, and the car immediately returns to predetermined floor and parks with door opened.	FER *9	☑	☑	☑	☑
Operation by Emergency Power Source - Sole Automatic	When normal power supply breaks, the pre-assigned cars will be powered by the emergency power source of the building and automatically travel to the predetermined floors in order. Once all cars have arrived at the predetermined floors, the specified car can operate normally.	OEPS-SA *10	☑	☑	☑	☑
Monitoring System	This system uses computer to monitor the elevator's operation and position state, and provide operation commands as necessary.	SMOS-II	☑	☑	☑	☑
Door Operating Features						
Door Close Limit Switch on Start	When the car doors can not close completely, they will reverse and open.	CLTS	☑	☑	☑	☑
Double Door Operation	When car doors are in open state, if there is no car call and landing call in forward direction and the landing call in reverse direction of this floor has been registered, the car doors will close and then immediately open again.	DDOP	☑	☑	☑	☑
Extended Door-open Button	Press and hold this button can extend door-open time.	DKO-TB	☑	☑	☑	☑

Feature	Description	Code	1C-2BC	2C-3M2	3-4C ITS-2	3-8C ITS-2 00
Door Operating Features						
Door Load Detect	If the car doors cannot fully open or close due to overload, the doors will act in reverse direction.	DLD	☑	☑	☑	☑
Not Door Open Feature	If car doors are blocked while opening, they will close immediately.	DONG	☑	☑	☑	☑
Automatic Door-open Time Adjustment	Automatically adjust door-open time according to landing calls or car calls.	DOT	☑	☑	☑	☑
Door Close Torque Up Control	When car doors encounter extra resistance while closing, the door system will automatically increase the torque.	DTC	☑	☑	☑	☑
Expediting of Door Close	After the car has stopped at a station and the doors has opened, pressing Close button can make the doors to close immediately.	EDC	☑	☑	☑	☑
Door Nudging Feature	If the door-open time exceeds the predetermined value, the car will temporarily ignore the action of non-contact door sensor and close the door forcibly.	KNDG	☑	☑	☑	☑
Multi-beam Safety Edge	Safety edge with multi-beam. Provide double protection by multi-beam and safety edge. During door closing, when a passenger or object is detected, the doors will open again.	MBS	☑	☑	☑	☑
Door Nudging Feature - with buzzer	If the door-open time exceeds the predetermined value, it will give alarm sound to alert the passenger and try to close the doors.	NDG *11	☑	☑	☑	☑
Repeated Door-Close	If car doors are blocked while closing, the elevator will repeat the closing action until the debris is removed.	RDC	☑	☑	☑	☑
Reopen with Hall Button	During door closing, when hall calling button in the same direction is pressed, the doors will reopen.	ROHB	☑	☑	☑	☑
Information and Display Features						
Voice Announce Device	Voice announce device (Chinese) informs the passengers of related elevator information.	AAN-S01 *12	☑	☑	☑	☑
Voice Announce Device	Voice announce device (Chinese and English in turn) informs the passengers of related elevator information.	AAN-S02 *12	☑	☑	☑	☑
Voice Announce Device	Voice announce device (English) informs the passengers of related elevator information.	AAN-S03 *12	☑	☑	☑	☑
Car Arrival Chime (Car)	The chime prompts the passengers the car has arrived at the destination floor. (The chime is installed on the car roof and floor)	AECC	☑	☑	☑	☑
Immediate Prediction Function	Once a passenger has registered a landing call, it will immediately select an elevator most suitable for responding this call and inform the passenger via a visual/audio signal.	AIL	—	—	—	☑
Automatic Operation Signal Light (Hall)	The landing indicator displays the elevator is in automatic operation state.	AULT *13	☑	☑	☑	☑
Signal Interface Device	Outputs basic operation state signal of the elevator via this device	BA *14	☑	☑	☑	☑
Bypass Signal Light (Hall)	The landing indicator displays the elevator is in "Bypass operation" state.	BPL *13	☑	☑	☑	☑
Direction Arrows in Car	Indicates running direction with arrows in the car.	DAC	☑	☑	☑	☑
Direction Arrows on Hall	Indicates running direction with arrows on the hall.	DAH	☑	☑	☑	☑
Door-Close Button Response Light	The Door-Close button light illuminates at the same time when this button is pressed.	DCR	☑	☑	☑	☑
Extended Door-Open Button Light	When the Extended Door-Open button is pressed, the indicator light illuminates for certain period.	DKOL	☑	☑	☑	☑
Door-Open Button Response Light	The Door-Open button light illuminates at the same time when this button is pressed.	DOL	☑	☑	☑	☑
Elevator Counter/Timer	Record number of runs and running time of the elevator.	ECT	☑	☑	☑	☑
Multimedia Display in Car	Can provide audio/video or other information for the passengers (installed in the car).	EMIDS-C *15	☑	☑	☑	☑
Multimedia Display on Hall	Can provide audio/video or other information for the passengers (installed on the hall).	EMIDS-H *15	☑	☑	☑	☑
Exclusive Service Indication	Display that the elevator is in exclusive service state.	EXCL	☑	☑	☑	☑
Fire Emergency Return - Completed	A CP signal is outputted after the FER running is completed.	FER-CP *16	☑	☑	☑	☑
Flashing Hall Lantern	Flashing lantern indicates arrival of car and its running direction.	FHL	—	—	—	☑
Hand Operation Signal Light	Hand Operation Signal Light indicates the car is operating under inspection operation.	HANDL	☑	☑	☑	☑
Interphone	In emergency, persons in car, on car top, or in pit can use this device to communicate with persons in machine room or monitoring room.	ITP *17	☑	☑	☑	☑
ITV cable (analog)	The cable used for video camera (analog) installed in the car for user to monitor the real image in the supervisory room.	ITV-A *18	☑	☑	☑	☑
ITV cable (digital)	The cable used for video camera (digital) installed in the car for user to monitor the real image in the supervisory room.	ITV-D *18	☑	☑	☑	☑
ITV cable (for SMOS)	The cable used for video camera equipped with SMOS system.	ITV-S *18	☑	☑	☑	☑
Operation by Emergency Power Source - Completed	A CP signal is outputted after the operation by emergency power source is completed.	OEPS-CP *19	☑	☑	☑	☑
Overload Indication in Car	When the elevator is overloaded, the overload indicator lamp illuminates.	OLHL	☑	☑	☑	☑
Out-of-Service Indication	Indicate the elevator is out of service on the hall.	RESL *13	☑	☑	☑	☑
Group Control Features						
Car Assignment Tune	In group control, the group control system adjusts car assignment according to actual situation in real time.	CAT	—	—	—	☑
Congested-Floor Service	When temporary congestion occurs due to meeting or other events, the system will try its best to arrange cars to the congested floor.	CFS	—	—	☑	☑
Car Nearest Priority Service	When responding landing call, the car nearest to the floor is assigned first.	CNPS	—	—	—	☑
Energy-saving Operation (Number of cars)	While considering passenger flow volume and meeting passengers' demand, when the elevators' service level has exceeded the specifications, the system will reduce number of cars put into service to save energy.	ESO-N	—	—	—	☑
Special Floor Forced Stop	Cars passing a certain floor are forced to stop at this floor.	FFS *20	☑	☑	☑	☑
Main Floor Parking	When there is no landing call or car call, the car returns to main floor and parks there.	MFP	☑	—	—	—
Strategic Overall Assignment	For group control elevators, the cars park dispersely at the main station and middle floor.	OHS	—	☑	☑	☑
Prevention of Simultaneous Running	This feature prevents simultaneous running within rapid running region of elevators installed in the same well to boost noise in the car.	PRS	—	—	☑	☑
Peak Traffic Control	To alleviate temporary peak traffic, heavy traffic floors (top floor or main floor) will be given priority service.	PTC	—	—	☑	☑
Specified Car Priority Service	Specified car is sent first for the landing call from specified floor in group control system (e.g. glass elevator or the elevators with basement service).	SCPS	—	—	—	☑
Specified Floor Priority Service	Provide preferential car service to a specified floor when a hall call is made at that floor.	SFPS	—	—	—	☑
Main Floor Changeover Operation	Main floor can be changed by pressing the Changeover switch.	TFS *1	☑	☑	☑	☑
Light-loaded Car Priority Service	When the traffic is light, the car with no or light load (load is less than 10%) is assigned first.	UCPS	—	—	—	☑
VIP Service	A specified car can be withdrawn from group service for special VIP service.	VIP-S *21	—	—	☑	☑

Remarks:

- *1 Nonstandard
- *2 Optional in the case where the number of landing stations is equal or more than 5 and SCS-IC feature is not provided.
- *3 Optional in the case where SCS-IC feature is provided.
- *4 Non-standard configuration. NS setting floor shall be specified.
- *5 When two or more elevators are in parallel or group control, the non-service floor of each elevator shall be consistent.
- *6 Only one of RCS and RET can be selected. The consumer or SMOS-II shall provide a dry contact signal to the control cabinet. The interface for that feature has been reserved in the control cabinet.
- *7 This does not apply when equipped with SCS-IC feature.
- *8 Distance to the adjacent floor will not be greater than 16m at the speed of 1m/s, other distances won't be greater than 20m.
- *9 The consumer provides NO dry contact signals of normal and emergency power sources respectively as well as dry contact signals for automatic control. These signals must be provided to the control cabinet in the machine room.
- *10 Users are required to provide the normally open dry contact signals of normal and backup power supply, and also to provide automatic control dry contact signals; the users shall provide these signals to the machine room control cabinet.
- *11 Applicable when car arrival chime is selected.
- *12 Only one of AAN-S01/S02/S03 can be selected at most.
- *13 Only one of AULT/BPL/RESL can be selected at most.
- *14 BA output: open collector outputs; Output signals are UP, DOWN, integrated fault, landing station code signals. he output signal terminals are in the control cabinet in the machine room. No RS232/RS485 output.
- *15 Nonstandard. No RS232/RS485 output.
- *16 Standard when FER is provided. Output in the control cabinet.
- *17 The customer is responsible for the cables from the machine room to the monitoring room and their installation.
- *18 Either ITV-A, ITV-D or ITV-S can be selected but one feature at most.
- *19 Optional when OEPS-SA is provided.
- *20 Mandatory landing floor shall be specified.
- *21 Non-standard, applicable for other than 2D2C, and 3C-ITS-21 or 4C-ITS-21 is selected. Installation floor and setting floor for VIP switches shall be specified.
- *22 ☑ Standard ☐ Optional

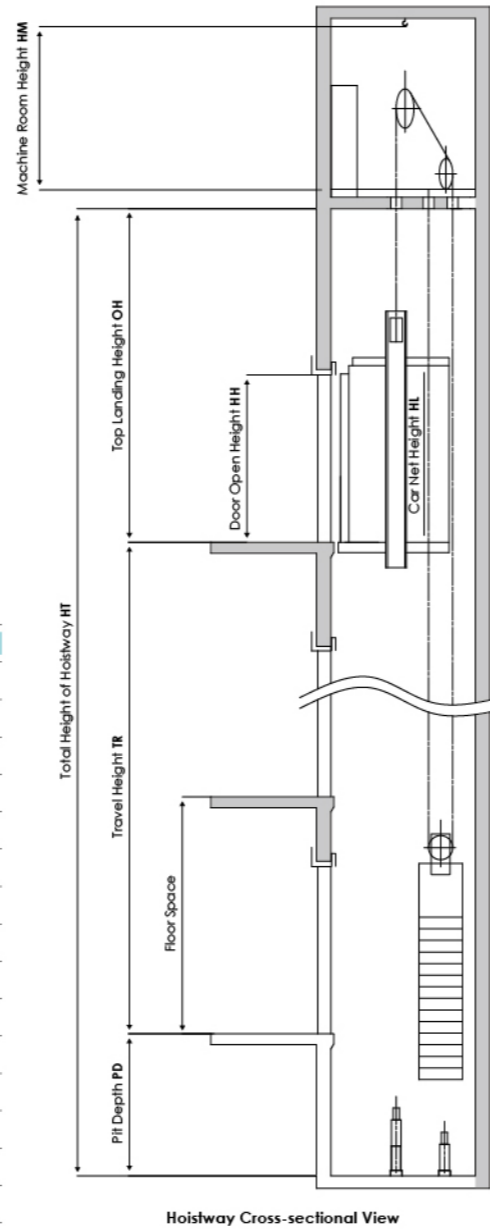
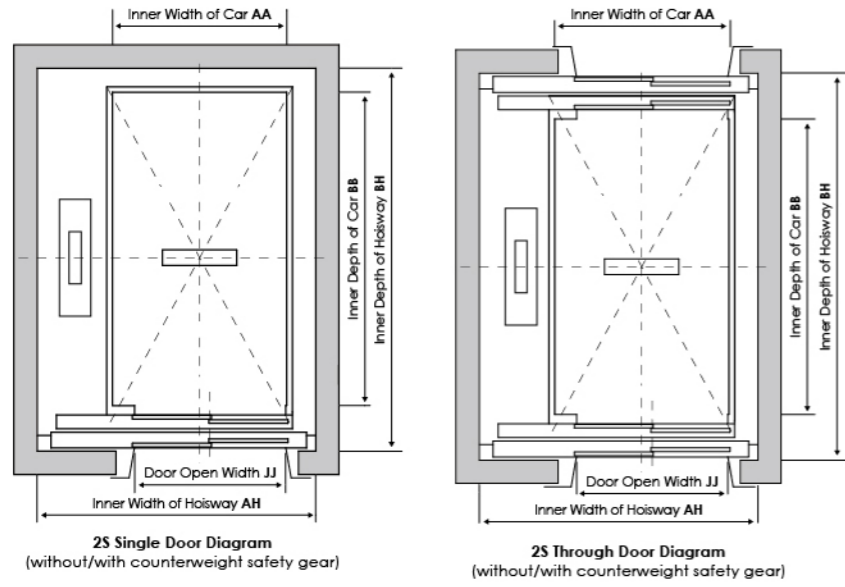

Item	Specifications		Remarks
Capacity(kg)	1600	1800	
Inner Width of Car AA(mm)	1500	1500	
Inner Depth of Car BB(mm)	2300	2500	
Top Landing Height OH(mm)	≥4500	≥4500	When capacity is 1.0m/s.
	≥4600	≥4600	When capacity is 1.6m/s.
	≥4600	≥4600	When capacity is 1.75m/s.
	≥4700	—	When capacity is 2.0m/s.
Door Open Width JJ(mm)	1200	1200	Two panel sliding door
	1100	1100	Center opening door
Door Open Height HH(mm)	2100	2100	
Pit Depth PD(mm)	≥1370	≥1370	When capacity is 1.0m/s.
	≥1360	≥1360	When capacity is 1.6m/s.
	≥1390	≥1390	When capacity is 1.75m/s.
	≥1490	—	When capacity is 2.0m/s.
Inner Width of Hoisway AH(mm)	≥2370	≥2370	Center opening door, single side opening
	≥2370	≥2370	Side opening door, through opening
	≥2570	≥2570	Center opening door, single side opening
	≥2570	≥2570	Center opening door, through opening
Inner Depth of Hoisway BH(mm)	≥2725	≥2925	Center opening door, single side opening
	≥2954	≥3154	Side opening door, through opening
	≥2650	≥2850	Center opening door, single side opening
	≥2810	≥3010	Center opening door, through opening
Inner Width of Machine Room AM(mm)	≥2370	≥2370	Center opening door, single side opening
	≥2370	≥2370	Side opening door, through opening
	≥2570	≥2570	Center opening door, single side opening
	≥2570	≥2570	Center opening door, through opening
Inner Depth of machine room BM(mm)	≥2725	≥2925	Center opening door, single side opening
	≥2954	≥3154	Side opening door, through opening
	≥2650	≥2850	Center opening door, single side opening
	≥2810	≥3010	Center opening door, through opening

Note:
 1. The civil engineering dimensions in the above table are calculated according to the car net height HL=2300
 HH=2100, when HL>2300 or HH>2100, please refer to civil engineering information.
 2. Refer to files of civil construction for AA, BB, HL, HH applicable to standard elevator.

Item	Specifications				Remark
Speed(m/s)	1	1.6	1.75	2	
Capacity(kg)	1800	1800	1800		
	1600	1600	1600	1600	
Travel Height TR(m)	3.4-55	7.3-90	7.3-90	9.1-120	
The Number of Stops (Stations)	2-18	2-32	2-32	2-36	
Operation Mode	1C~2BC, 2C~SM21, 2C~ITS-21, 3C~ITS-21, 4C~ITS-21				
	3C~ITS-2100, 4C~ITS-2100, 5C~ITS-2100, 6C~ITS-2100, 7C~ITS-2100, 8C~ITS-2100				Nonstandard
Control Mode	VFH-L				
Door Opening Type	1D1G				
	1D2G, 2D2G				
Door Opening Mode	Center opening, side opening				
Door Opening Bearing	Left opening, Right opening				Side opening
Dynamic Power	380V 50Hz 3-phase 5-wire				
Lighting Power	220V 50Hz single phase				
Minimum Landing Height (mm)	2800				In the case where the nosing is concrete and provided by others. Door opening height is 2100, car net inner height is 2200. For details please refer to the civil drawing.
	2600				In the case where the nosing is steel and provided by SMEC. Door opening height is 2100, car net inner height is 2300. For details please refer to the civil drawing.
Nosing (Door Sill Bracket)	Concrete nosing by others. Steel nosing by SMEC.				
Door Jamb Temporary Sealing Plate	Provided, Not provided				
Car Protective Device	Provided, Not provided				
Delivery Code	SMT				
CWT Position	Side Mounted				
CWT Safety Gear	Provided, Not provided				
Display Range of Landing	B, B1, B2, B3, G, M, -1, -2, -3, 1, 2, 3, 4, 5, 6, 7, 8, 9, 10, 11, 12, 13, 14, 15, 16, 17, 18, 19, 20, 21, 22, 23, 24, 25, 26, 27, 28, 29, 30, 31, 32, 33, 34, 35, 36, 37, 38, 39, 40, 41, 42, 43, 44, 45, 46, 47, 48				